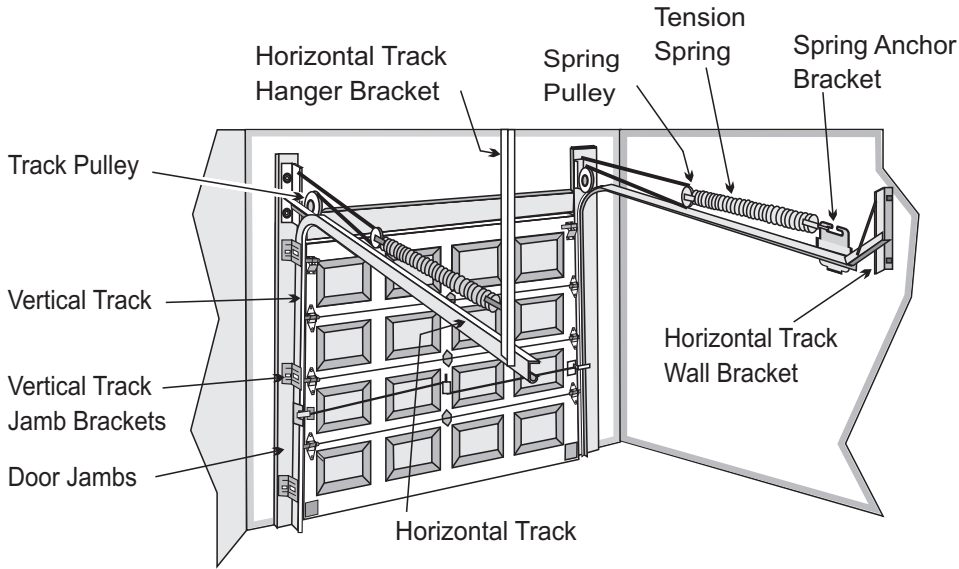
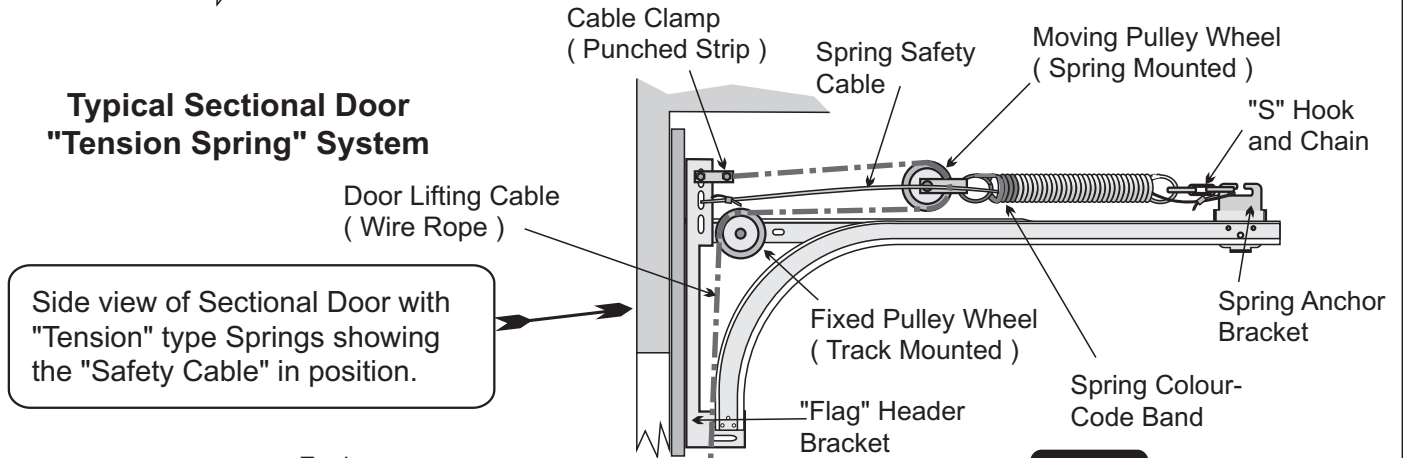


# SECTIONAL DOOR EXPRESSIONS



**Fig. 1**

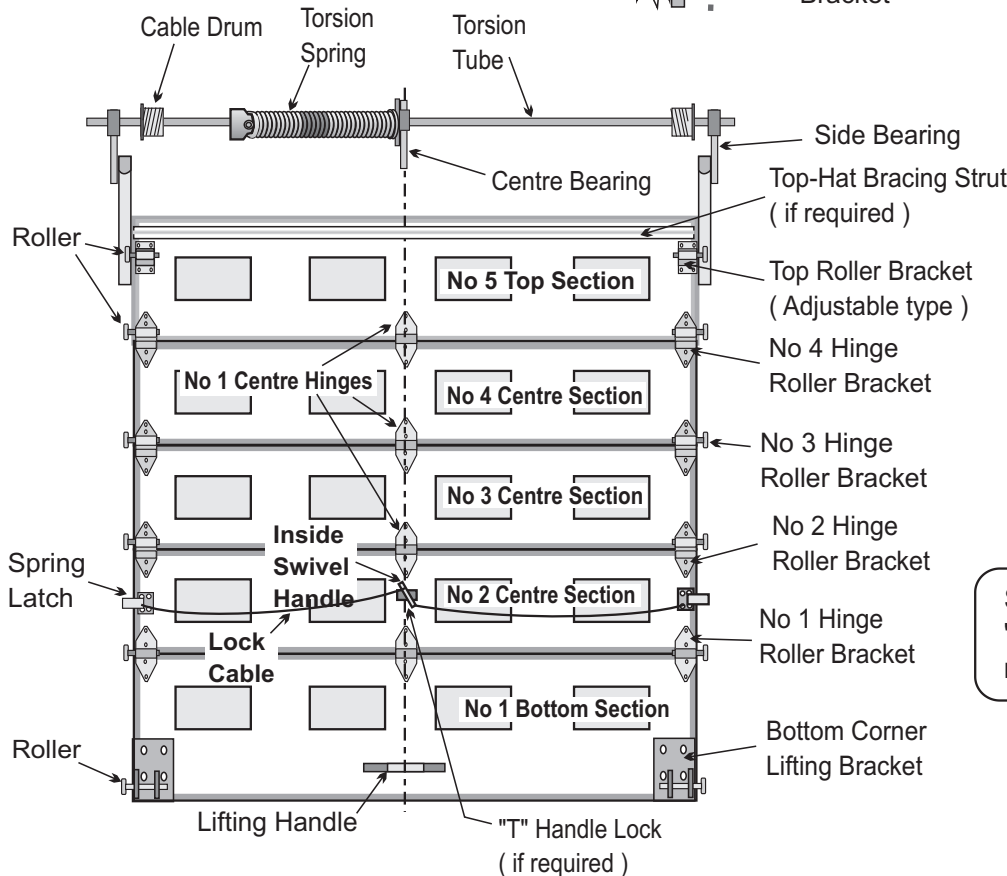
**Typical Sectional Door "Tension Spring" System**



**Fig. 2**

**Typical Sectional Door "Tension Spring" System**

Side view of Sectional Door with "Tension" type Springs showing the "Safety Cable" in position.



**Fig. 3**

**Typical 5 Section Door "Torsion Spring" System**

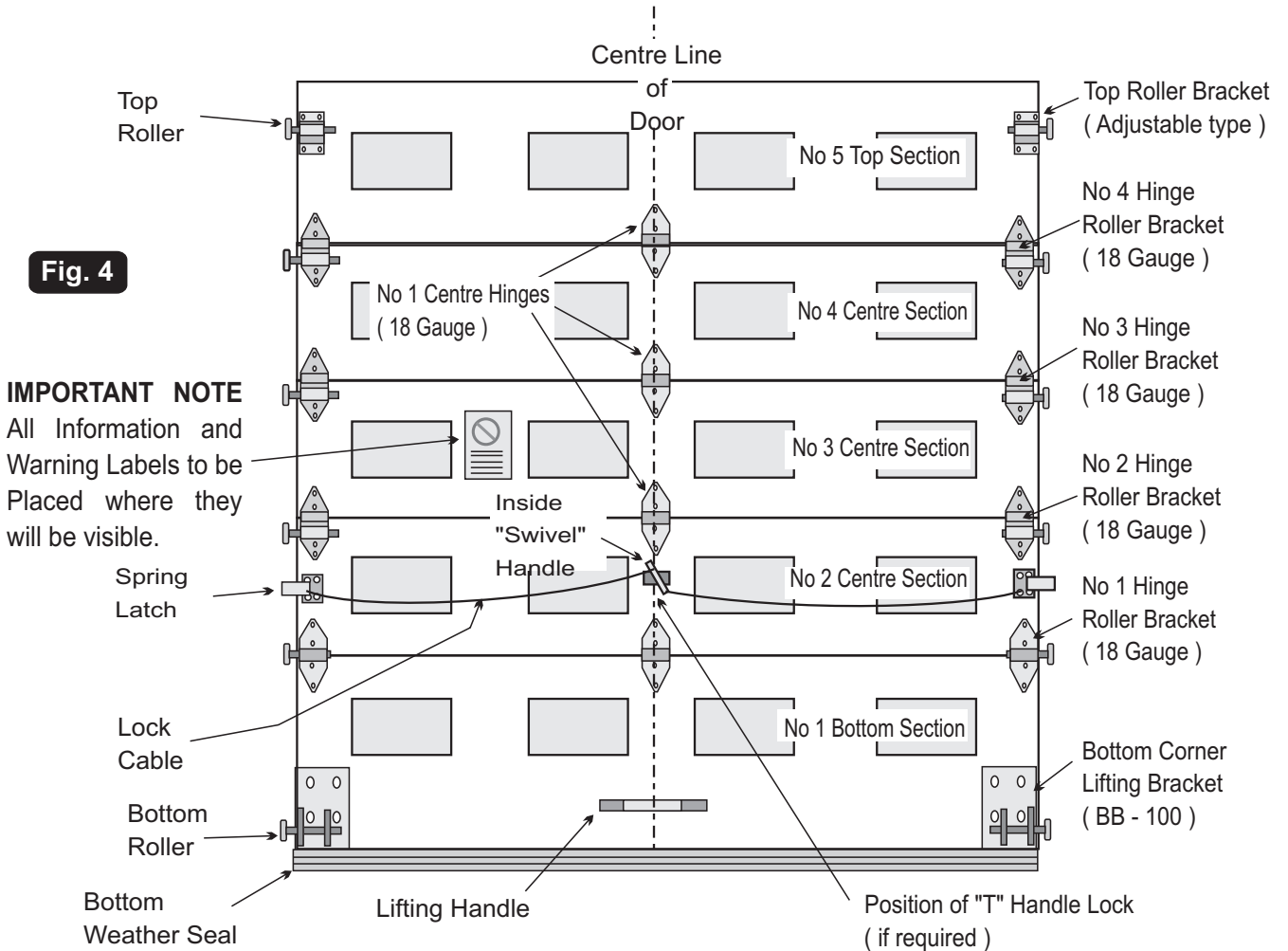
Sectional Door with "Torsion" type Springs mounted above the door.

## SINGLE SECTIONAL DOOR HARDWARE LAYOUT

### Typical Layout of Hardware for a Standard Single Size Sectional Door

**Notes:-**

- 1 Depending on the size of the door, its mass and construction, the quantity of **No. 1 Centre Hinges** may differ from the layout shown here.
- 2 If the door has more or less than **5 sections** as shown here, the size of the **"Side Roller Hinge Bracket"**, ( i.e. hinge number ), will vary accordingly.  
Example, a door with **6 sections** will have up to a **No. 5 Hinge**, a **7 section door** up to a **No. 6 Hinge** and so on, whereas a **4 section door** will have up to a **No. 3 Hinge** only.



**Fig. 4**

**IMPORTANT NOTE**  
All Information and Warning Labels to be Placed where they will be visible.

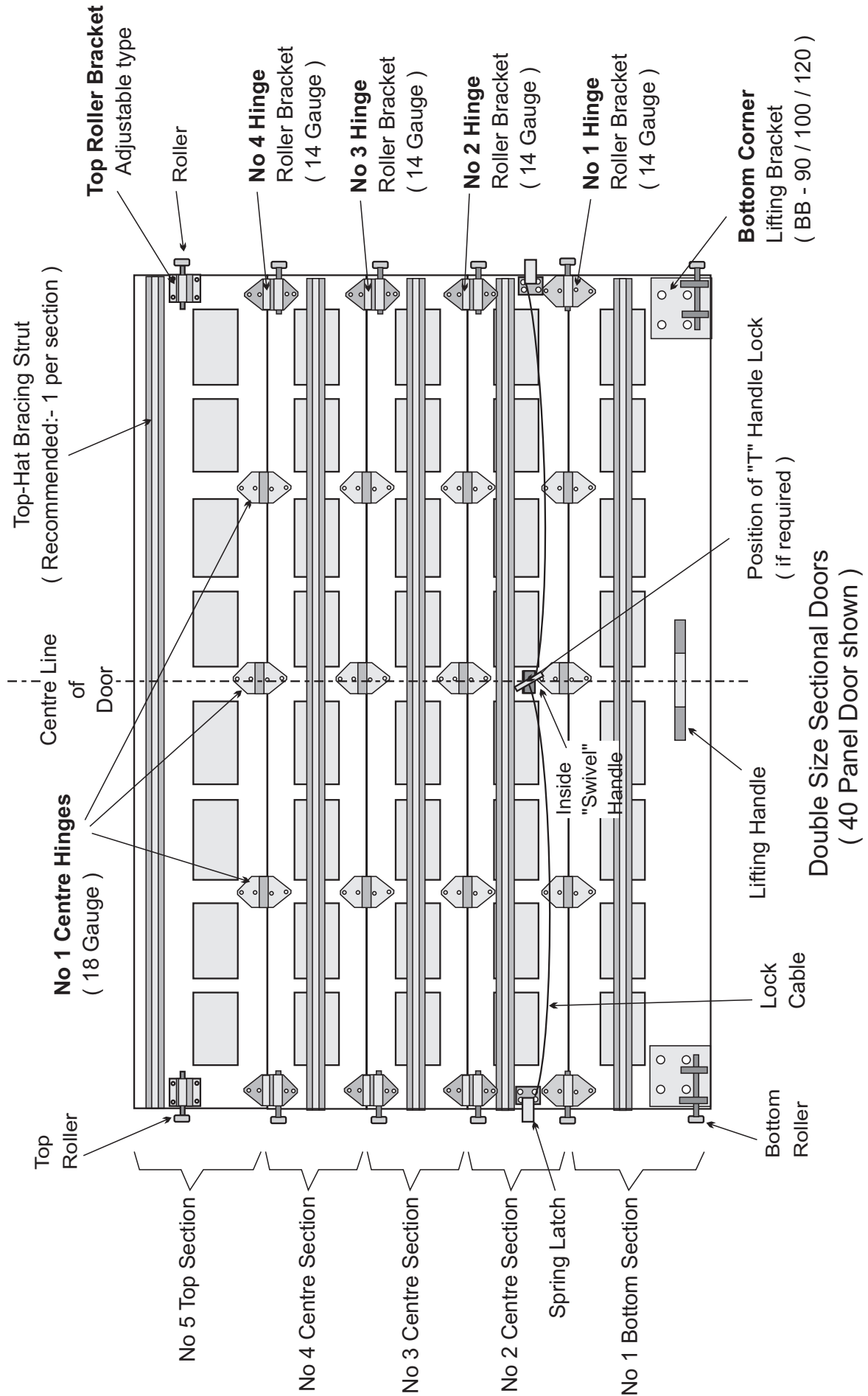
Typical Hardware Layout for Single Size Sectional Door

**General Notes - Applicable to all Sectional Doors**  
**INDUSTRY STANDARDS**

The colours **"red"** and **"black"** are used to denote whether a component is **"left"** hand or **"right"** hand respectively.

When applied to items such as Cable Drums, the Winding Cones on torsion springs, "Flag" Header Brackets, in fact any component which is made to be **"handed"**, then, when standing inside the garage looking out, ..... **"black"** is on the RHS, and .....  
..... **"red"** is on the LHS

**DOUBLE SECTIONAL DOOR  
HARDWARE LAYOUT**



**Fig. 5**

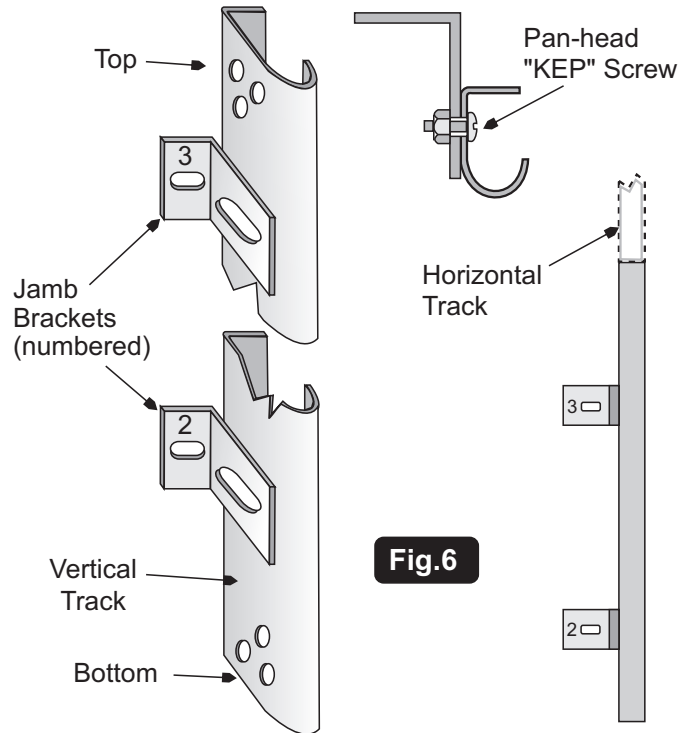
## SECTIONAL DOOR INSTALLATION

### Step 1 Assembling the Vertical Tracks

Fix the **Vertical Track - Jamb Mounting Brackets** as shown in Fig. No 6

#### Note:-

- 1 The **Jamb Brackets** are numbered **1, 2, 3, 4, 5, etc.** Depending on the thickness of the door section and the overall height of the door, the door manufacturer will recommend various combinations of **Jamb Brackets**, e.g. Nos. 1 & 2, or Nos. 3 & 4, or Nos. 3, 4, and 5. Whatever the combination, the **Jamb Brackets** are always assembled onto the **Vertical Track** with the "lowest" number bracket at the lowest mounting position on the track.
- 2 Standard height doors normally have **2 (two)** jamb brackets per side. The number of **Jamb Brackets** increases with an increase in door height.

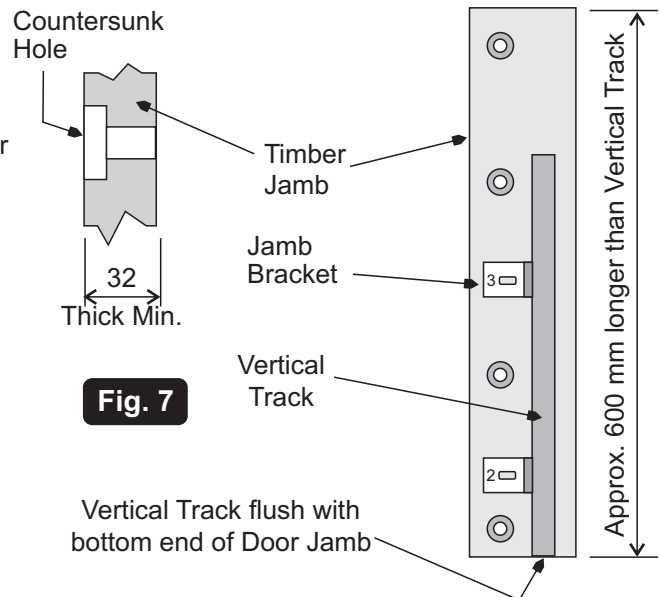


**Fig.6**

### Step 2 Timber Jamb, ( Facia Boards )

Timber Jamb, ( Pine, Saligna or Meranti are suitable), and ideally should be **125 - 150 mm** Wide x not less than **32 mm** thick. Length to suit the size of the door. For a standard height door, ( 2135 mm H ), the recommended length is approximately. **2500 mm**.

Mark out the positions for the Wall Fixing Screws and drill the holes. Use the assembled vertical tracks as a template.



**Fig. 7**

#### Useful Tip:-

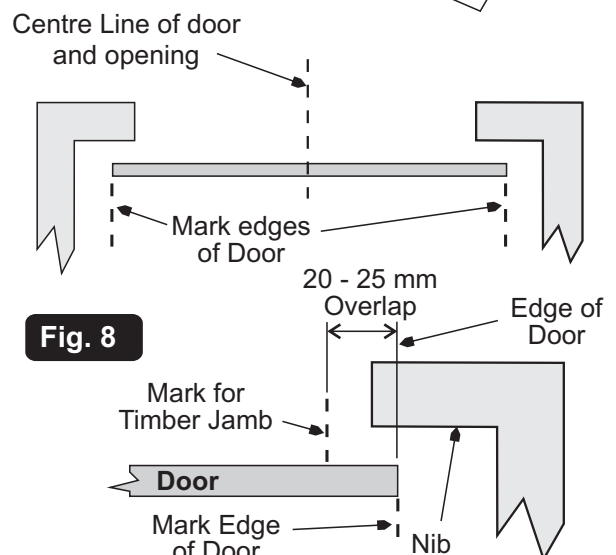
*Countersink the holes so that the heads of the screws are flush with the timber face. It makes adjustment of the tracks easier at a later stage.*

### Step 3 Marking Out the Garage

- 1 Place the No. 1 Bottom Section of the door in the opening and centre it. The door should *overlap* the Nibs equally at each side !
- 2 Mark out the position of the door on the floor.
- 3 Make a mark each side of the door **20 - 25 mm** into the opening. This is the position for the Timber Jamb.

#### NOTE:-

The Jamb must overlap the door sections by at least **20 mm**.



**Fig. 8**

## SECTIONAL DOOR INSTALLATION

### Step 4 Fixing the Timber Jambs

- 1 Set the Jambs in position up to the marks on the floor. Use a spirit level to set the Jambs vertical, ( i.e. plumb ).
- 2 Mark out the positions of the holes for the wall fasteners. Drill holes **10mm x 75mm** deep in the wall.
- 3 Use the **M8 x 90mm** Hex-head Coach Screws and **M8 x 24** dia. Washers to fix the Jambs in place.

**NOTE:-**

**Use a minimum of 4 screws for a 2135mm high door. The spacing between the screws should not exceed 500mm.**

### Step 5 Setting The Levels ( Fig. 10 )

- 1 Set the Bottom Section into the opening and centre it.
- 2 Use a Spirit Level to set the Door Section level. Use pieces of packing as required.
- 3 If the floor is level continue with **Step No 6**
- 4 If the floor is out of level, proceed to **Step No 20**.

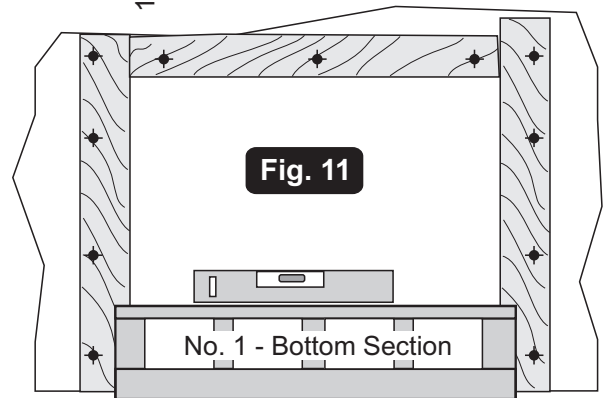
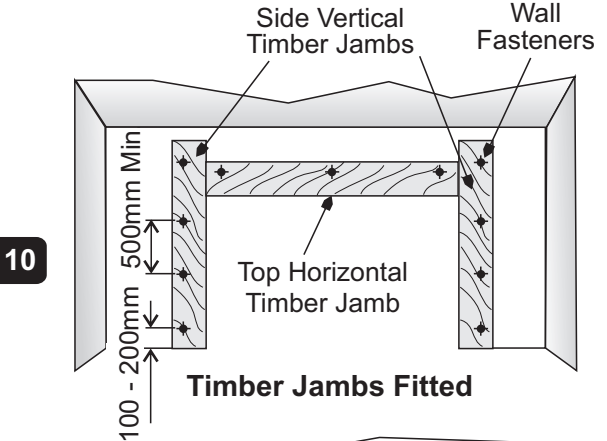
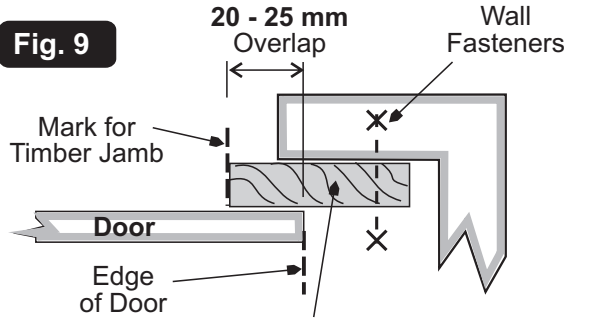
### Step 6 Attaching the Hinges and other Fittings to the Door Sections.

The Door Sections are numbered from the bottom up. ( See Fig No. 4 )

- 1 The Bottom Section is **No1**. The next one up is **No 2** and so on.
- 2 Lay out all the fittings. Note that the hinges are all numbered, e.g. **No 1, No 2, No 3**, etc.
- 3 **Start with the No. 1 Section !**  
Fix the **No 1** Roller Hinges and Centre Hinges to the **No 1** Section as shown. **The centre line of the hinge must line up with the split-line on the back face of the doors.**

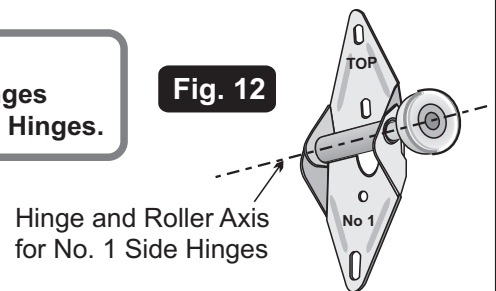
**IMPORTANT NOTES:-**

- a) For the **No 1 Hinges**, the hinge axis coincides with the roller axis.
- b) The **No 1 Hinges** also serve as **Centre Hinges** between all sections.
- c) The hinge must be positioned with the number to the bottom. The part of the hinge with the manufacturer's stamp or the word **"Top"** must be at the top.

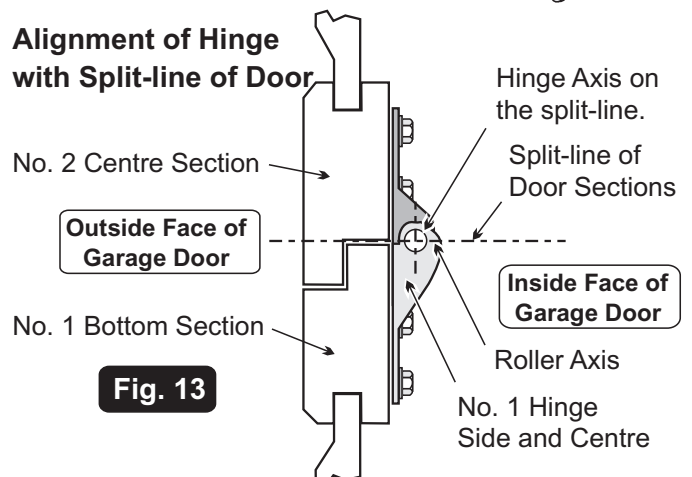


**Note:-**  
All Centre Hinges are No. 1 type Hinges.

**Fig. 12**



### Alignment of Hinge with Split-line of Door



## SECTIONAL DOOR INSTALLATION

### Step 7 Attaching the Bottom Corner Lifting Brackets to the Bottom Section.

- 1 The Bottom Corner Lifting Brackets are fixed to the No 1 door section. Fix the brackets to the bottom corners as shown in Fig 14.
- 2 **Attach the Lifting Cables, ( Wire Ropes ), to the Bottom Corner Lifting Brackets.**

#### TAKE NOTE:-

- a) *The brackets are "handed". The Cable Lug must be at the very bottom of the door. ( Fig 14 ).*
- b) *Ensure that the Bottom Corner Lifting Brackets are level with each other.*
- c) *It is very important to ensure that the hinges are properly aligned with the rebated edges of the door sections, i.e. they must not be "skew" or "off-centre".*

Door Lifting Cable  
( Steel Wire Rope )

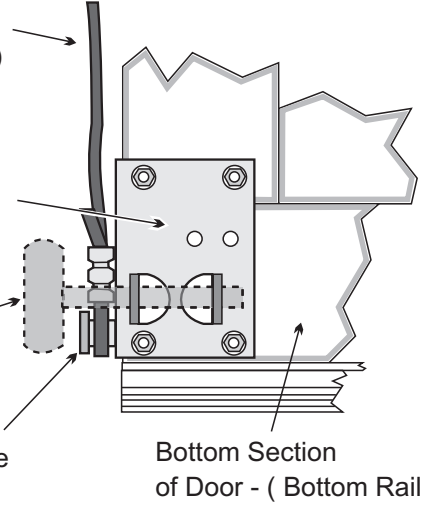
**Fig. 14**

Bottom Corner  
Lifting Bracket

Bottom  
Roller

"Milford" Pin or  
"Drilled" Pin type  
Lifting Lugs

Bottom Section  
of Door - ( Bottom Rail )



### Step 8 Lifting Handle and Bottom Weather Seal

- 1 Fix the **Lifting Handle** to the **No. 1 Section**, ( see Fig 4 ).
- 2 Fix the **Bottom Weather-seal** to the bottom edge of the **No. 1 Section**, ( see Fig. 15 ).

Outside Face of  
Garage Door

**Fig. 15**

Inside Face of  
Garage Door

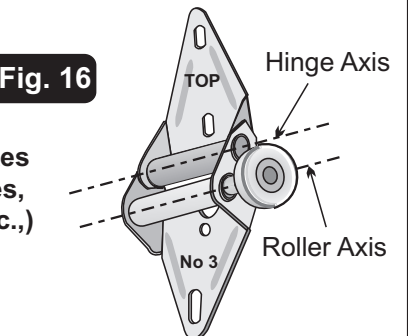
Fix Weather Seal to  
Bottom Rail of Door

Bottom Rail of  
No. 1 Bottom Section

Aluminium  
Retainer

Rubber Weather-strip  
( Lip to outside )

Registered Design  
Application Pending.



**Fig. 16**

Hinge and Roller Axes  
for other Side Hinges,  
( Nos. 2, 3, 4, etc., etc., )

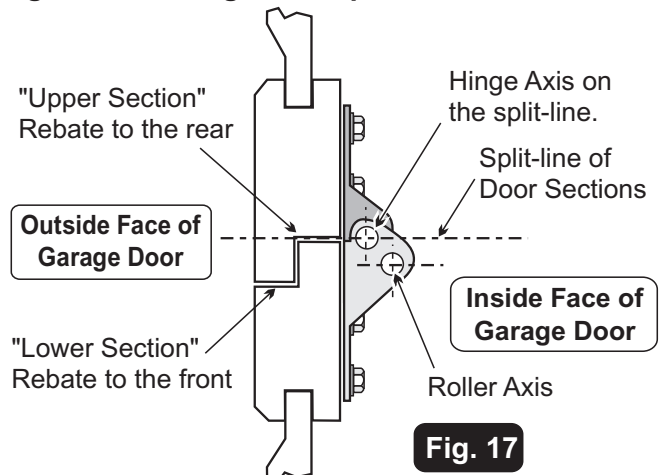
**Do not stack the sections into position in the opening until Step 13 !**  
**Only attach the hinges and other fittings to the door at this stage !**

### Step 9 No. 2 Section - No. 2 Hinge and Centre Hinges.

- 1 Fix the **No 2 Roller Hinges** in place, ( see Fig 4 ).
- 2 Fix the **Centre Hinges**, ( same as the No. 1 Hinges ) to the **No. 2 Section** as shown. ( Figures 4 & 20 ).

**See Fig 4. for the general layout of all the fittings on the door**

#### Alignment of Hinge with Split-line of Door



**Fig. 17**

## SECTIONAL DOOR INSTALLATION

### Step 10 Spring Latches, Inside Swivel Handle and "T" Handle Lock

- 1 **Spring Latches** are normally fitted to the No 2 Section. The latches must engage with the Striker Plates on the Vertical Track.
- 2 Fit the **Inside Swivel Handle** to the No 2 Section on the centre line of the door.
- 3 If an outside **"T" Handle Lock** is to be fitted, it will also be fitted to the No 2 Section.
- 4 Fit the **Lock Cable** as shown.
- 5 If a **"T" Handle lock** is required, drill the appropriate size hole through the door. The square shaft of the lock passes through the **Swivel Handle**.

#### TAKE NOTE:-

"T" Handle Locks are fitted to doors which:-

- a) *will not be automated, and .....*
- b) *to any automatic garage door which is installed in a garage which does not have a secondary access !!!*

### Step 11 Centre Section Panels.

( Fig. 20 )

- 1 Fit the hinges to the No 3 Section in the same way as for Section No 2.
- 2 Repeat the procedure for all remaining Centre Sections, ( i.e. Nos. 4, 5, 6 as required ).

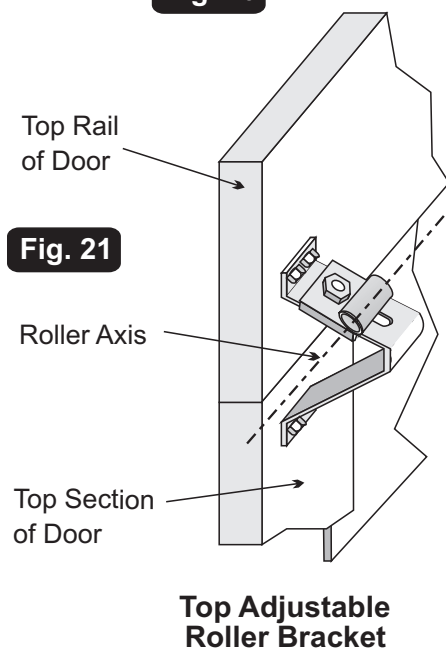
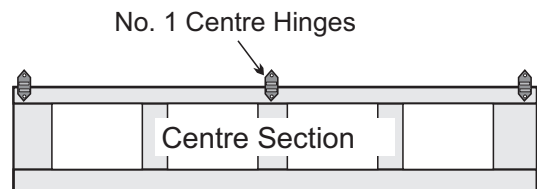
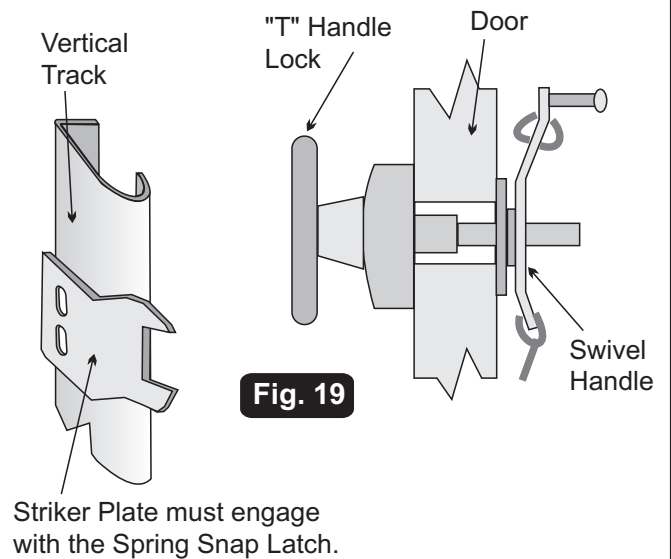
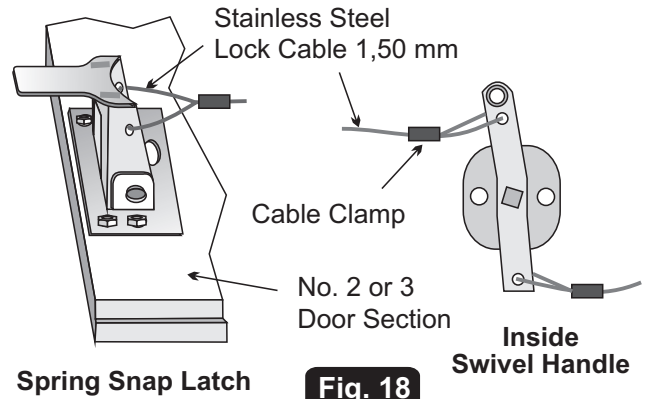
### Step 12 Top Section

( Fig. 21 )

- 1 Fix the **Top-Adjustable Roller Bracket 50 - 100 mm** below the top edge of the door.

#### NOTE:-

It is advisable to fit this bracket only when the Top Section is finally put in place in the opening. It will be easier to determine the best position for the Top Adjustable Roller Bracket,. ( i.e. when completing Step 16. )

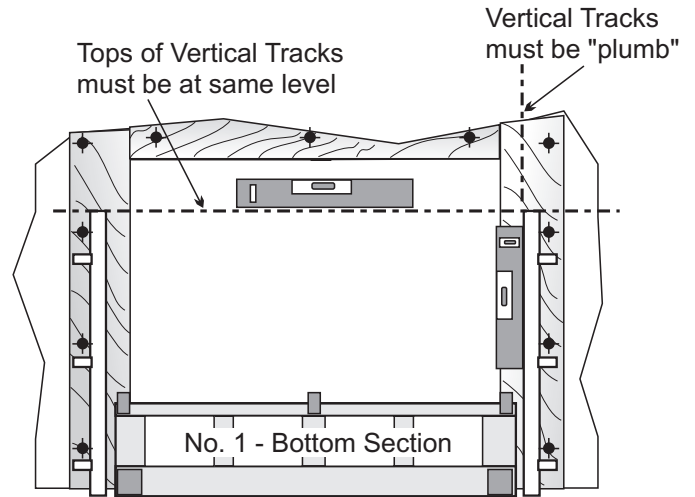


## SECTIONAL DOOR INSTALLATION

### Step 13 Setting Up the Vertical Tracks and No 1 Bottom Section.

( See Figures 22 & 23 )

- 1 Place the No 1 Bottom Section in the opening according to the reference marks made previously.
- 2 Place the Vertical Tracks with the Jamb Brackets attached adjacent to the section.
- 3 The edge of the Vertical Track should be **15 - 20 mm** from the edge of the door. Do not set the track too close to the door as the door must be allowed to **"float"** to some degree.
- 4 Make sure that the track is vertical, ( use the Spirit Level or a Plumb Bob ) -See notes below.
- 6 Fix the Vertical Track to the Door Jamb.



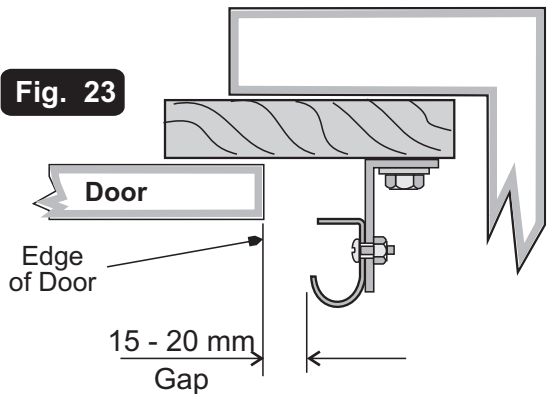
**Fig. 22**

#### IMPORTANT NOTE:-

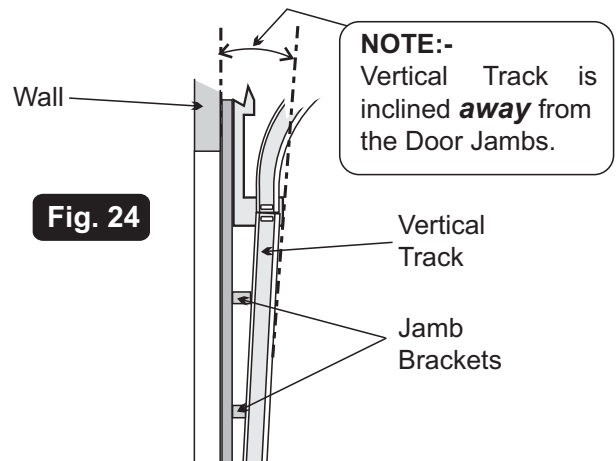
a) Make sure that the tops of the Vertical Tracks are at the same level. Not having the tracks accurately aligned is one of the main reasons that many sectional doors do not operate correctly !!!

b) **Do not fit the Horizontal Tracks until Step 15.**

c) The Vertical Tracks, when viewed from the side, are not **"exactly vertical"**, i.e. they are not parallel to the wall. The tracks must be inclined at a slight angle to the wall as shown in **Fig. 24**



**Fig. 23**



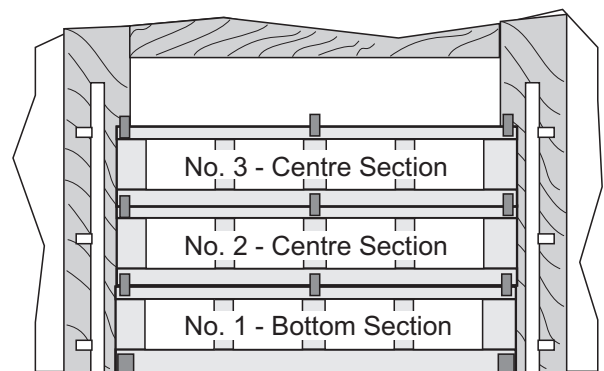
**Fig. 24**

### Step 14 Setting Up the Centre Sections.

( Fig. 25 )

- 1 Place the No. 2 Centre Section in place and fix the hinges between the 2 sections with the Hinge Fasteners provided.
- 2 Repeat the procedure with the rest of the Centre Sections, i.e. Nos. 3, 4, etc. )

**Do not fit the Top Section into place yet !  
This will be done in Step 16.**



**Fig. 25**

## SECTIONAL DOOR INSTALLATION

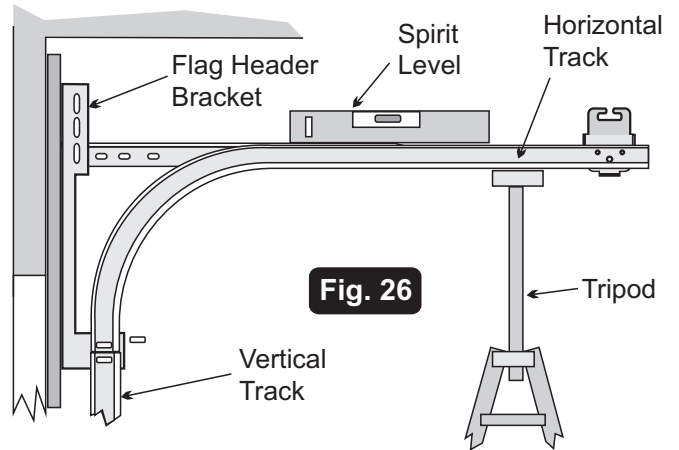
### Step 15 Setting Up the Horizontal Tracks.

( See Fig. 26 )

- 1 Fit only one side of the Horizontal Tracks.  
***This will make it easier to set the Top Section in place.***
- 2 Use the Tripods to support the Horizontal Track in place. Fix the curved section of the track to the Flag Header Bracket.
- 3 Fix the Flag Header Bracket to the top of the Vertical Track.

#### NOTE:-

The "Flag" Bracket is colour coded. "Red" is for the LHS and "Black" for the RHS.

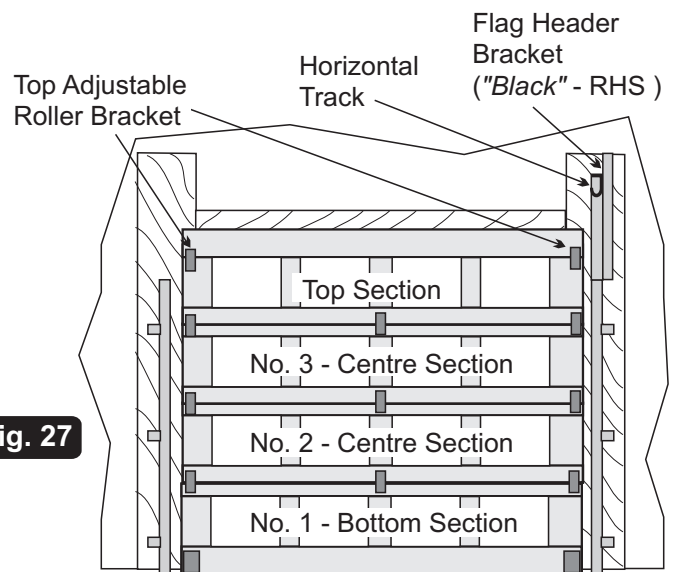


**Fig. 26**

### Step 16 The Top Section

( See Fig. 27 )

- 1 Set the Top Section in place.
- 2 Position the Top Adjustable Roller Brackets and fix them in place.



**Fig. 27**

### Step 17 Aligning the Horizontal Tracks

( See Fig. 28 )

- 1 ***Now ! ....*** Install the remaining Horizontal Track.

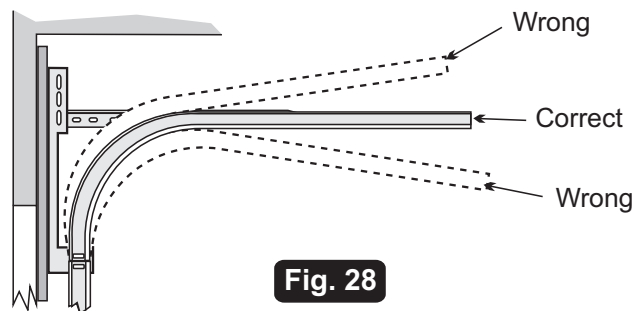
#### NOTES:-

***When installing the Horizontal Tracks, take care to ensure that ....***

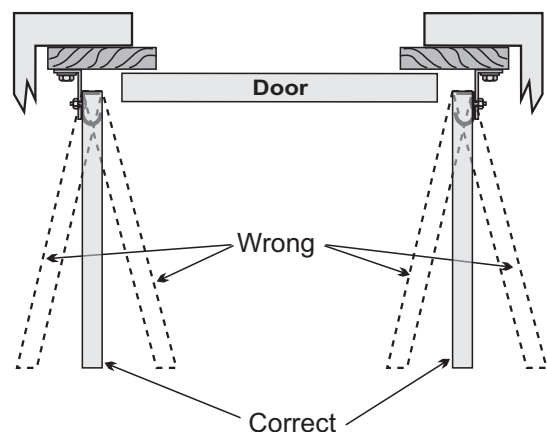
1) ..... ***the tracks are at the same height and are level to the floor, and parallel to each other !!!***

2) ..... ***the tracks must not converge towards or diverge away from each other !***

3) ..... ***also, the 15 - 20 mm gap between the edge of the door and the track is maintained for the Vertical and Horizontal Tracks.***



**Fig. 28**



## SECTIONAL DOOR INSTALLATION

### Step 17 ..... continued

- 2 Make up suitable wall or hanging brackets to support the Horizontal Tracks.

**"Ready-made"** brackets, such as the one shown in Fig. 29, are available "ex stock".

### Step 18 Tension Spring Assembly.

250 mm Radius Tracks ( Orange Code )  
 300 mm Radius Tracks ( Green Code )  
 ( Figures 30, 31, 33, 34 & 35 )

**Warning ! Warning ! Warning !**

**Exercise extreme caution when working with garage door springs.**

**There is a great deal of energy stored in the spring when it is under tension.**

**Never work on springs without the proper tools, knowledge and training.**

- 1 Assemble the Pulley with the "fork" fitting to the Spring.
- 2 Hook the Chain onto the Spring Anchor Bracket.
- 3 Pass the "S" Hook through the loop on the Spring.
- 4 Reeve the Lifting Cable from the Bottom Corner Lifting Bracket up the side of the door and over the Fixed Track Mounted Pulley.

**Note:-**  
**The Lifting Cable passes between the edge of the door and the Vertical Track.**

- 5 Clamp the end of the Lifting Cable to the "Flag" Header Bracket using the Clamping Strips.
- 6 **Before the spring can be hooked onto the Spring Anchor Bracket, the door must first be raised to the "open" position.**

### Safety Tip!

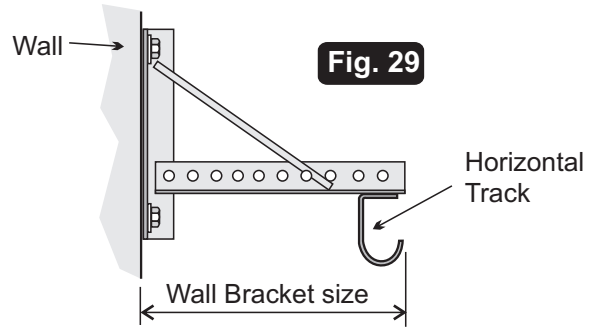
Secure the door in the open position by placing a "G" Clamp in the Vertical Track under the Door Roller.

**Warning ! - TENSION SPRINGS**

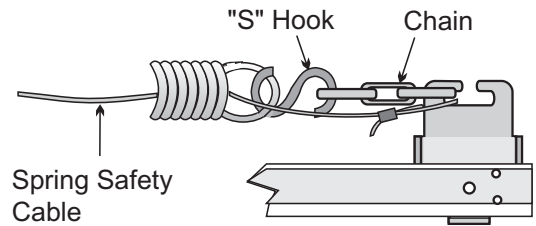
**Do not attempt to adjust the spring tension whilst the door is in the "closed" position !!!**

**When the door is closed, the spring is under maximum tension !!!**

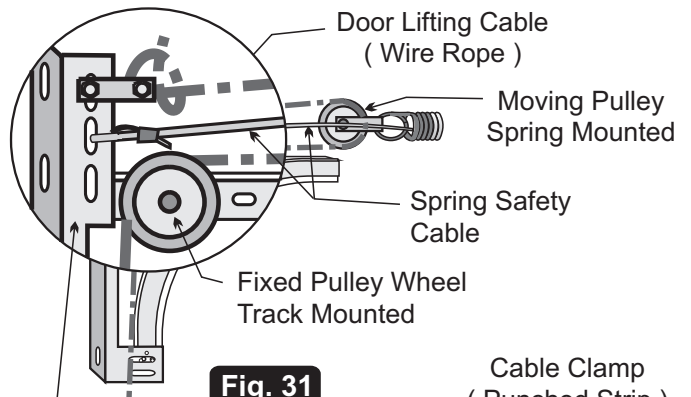
**Raise the door before making any adjustments to the springs !!!**



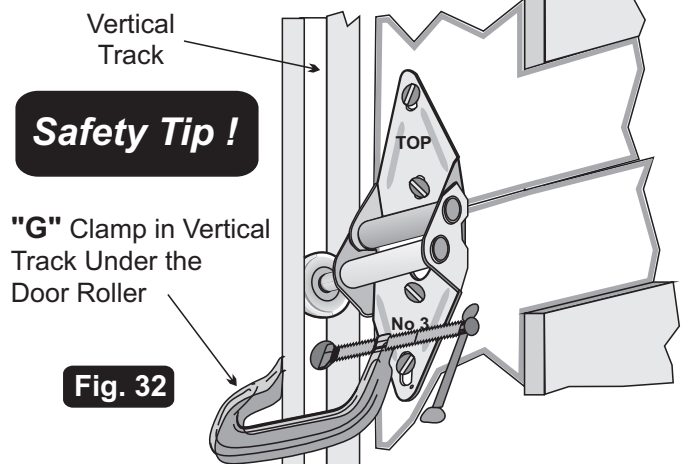
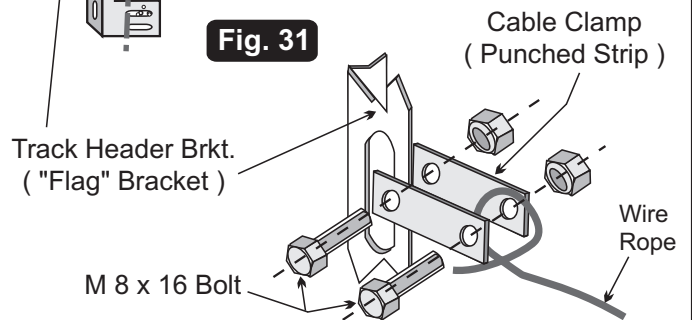
**Fig. 29**



**Fig. 30**



**Fig. 31**



**Fig. 32**

### Safety Tip !

"G" Clamp in Vertical Track Under the Door Roller

## SECTIONAL DOOR INSTALLATION

### Step 18 ..... continued

- 7 Pass the Spring Safety Cable through the spring. Anchor the Safety Cable to the Spring Anchor Bracket at one end and to the Flag Bracket at the other.

**Do not pull the Safety Cable taut !  
The Safety Cable must remain slack !**

- 8 Tension the spring by adjusting the length of the chain.

### Step 19 Tension Spring Assembly.

380 mm Radius Tracks - "Blue" Code

- 1 If 380 mm Radius Horizontal Tracks are being used, it is necessary to fit a Cable Clamp Anchor Bracket for attaching the Cable Clamp for the Door Lifting Cables and Spring Safety Cables.

#### NOTE:-

**380 mm Radius Horizontal Tracks, ( Blue code ), are used for 4 section door and on doors where the height of the door section exceeds 465 mm.**

**Caution ! Caution ! Caution !**

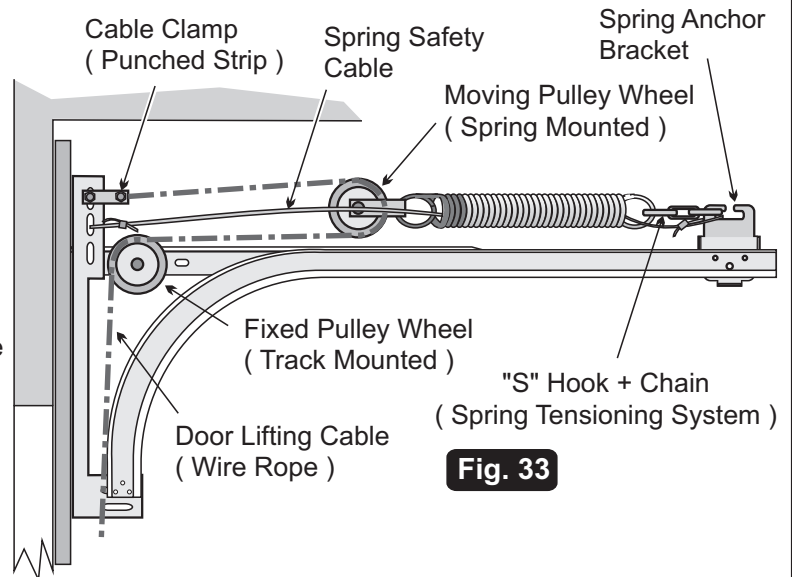
**Before lifting the garage door, check and re-check the following:-**

- 1) All fasteners are secure, especially those that secure the jambs to the wall and the track fasteners.
- 2) Pay particular attention to Track Hanger Brackets and Spring Anchor brackets.
- 3) Make sure the Door Lifting Cables and the Safety Cables are secure.

#### Warning!

**Never place your fingers between the sections of the door !**

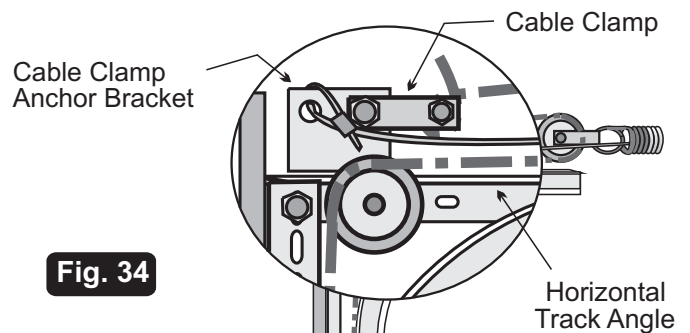
**Serious Injuries may be sustained !**



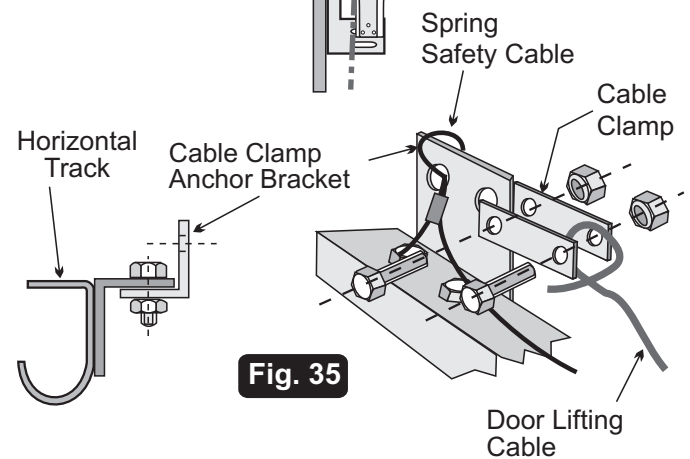
**Fig. 33**

### Tension Spring Assembly.

380 mm Radius Tracks ( Blue Code )

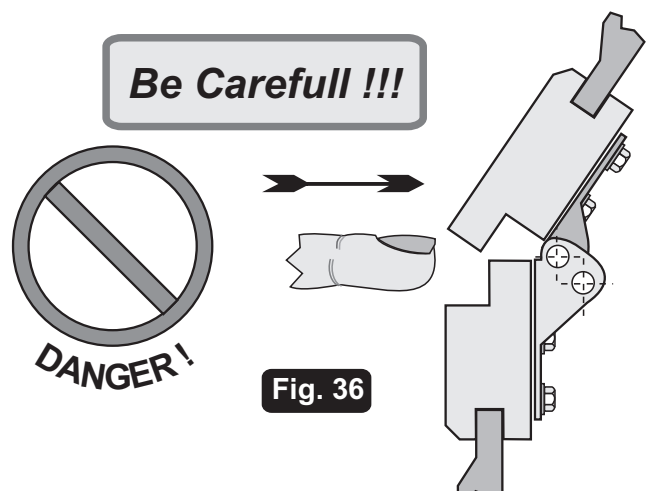


**Fig. 34**



**Fig. 35**

**Be Carefull !!!**



**Fig. 36**

## SECTIONAL DOOR INSTALLATION GARAGE FLOOR NOT LEVEL

### Step 20 Setting Up the Vertical Tracks and No.1 Bottom Section.

**Method 1 - ( preferred method ) - ( See Fig 37 )  
.... for installations with adequate "headroom"**

- 1 Place the No 1 Bottom Section in the opening according to the reference marks made for the Door Sections and Door Jamb and set to a "level" position.
- 2 **Start at the side where the floor is "highest" !** Place the Vertical Track with the Jamb Brackets attached, adjacent to the section. Follow the steps described previously to level and set the correct clearances for the tracks.
- 3 Place the opposite side Vertical Track in position using the No 1 Bottom Section as a reference to get the correct levels.

#### IMPORTANT NOTES:-

**a) Make sure that the tops of the Vertical Tracks are at the same level.**

**b) Bottom Door Stopper.**

**Install a Bottom Door Stopper underneath the Vertical Track on the "low" floor side to prevent the Bottom Roller from coming out of the track.**

**c) All other procedures for installing the door are as described previously !**

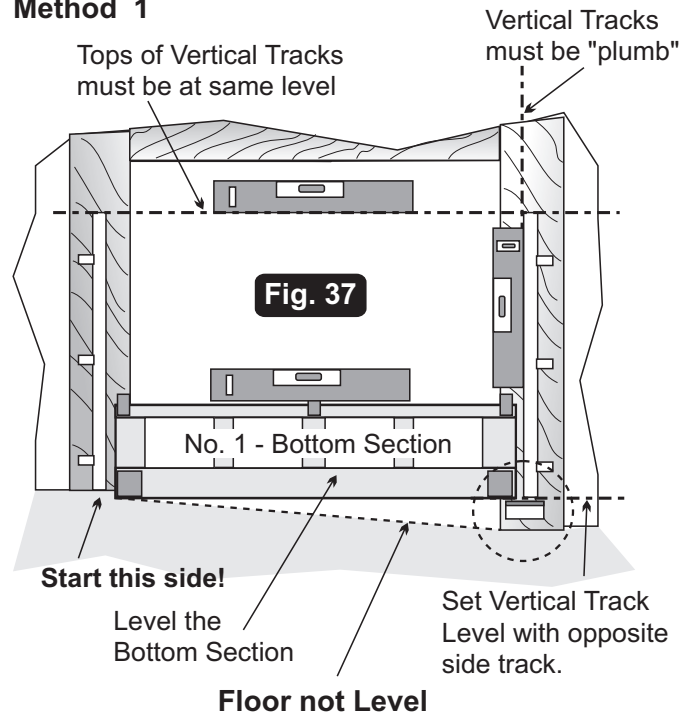
### Step 21 Setting Up the Vertical Tracks and No.1 Bottom Section.

**Method 2 - ( alternative method ) - (See Fig 38)  
..... for installations where the available "headroom" is limited.**

- 1 With the No. 1 Bottom Section in place, measure the maximum gap under the door.
- 2 **Start at the side where the floor is "lowest" !** Place the Vertical Track with the Jamb Brackets attached, adjacent to the section. Follow the steps described previously to level and set the correct clearances for the tracks.
- 3 Cut a length off the opposite side Vertical Track equal to the gap under the door. Fix the track in place. Complete the installation of the door.

**Do not cut more than 50 mm off the Vertical Track !**

#### Method 1

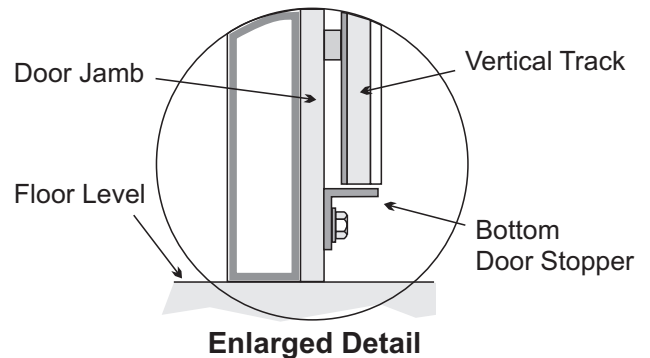


Start this side!

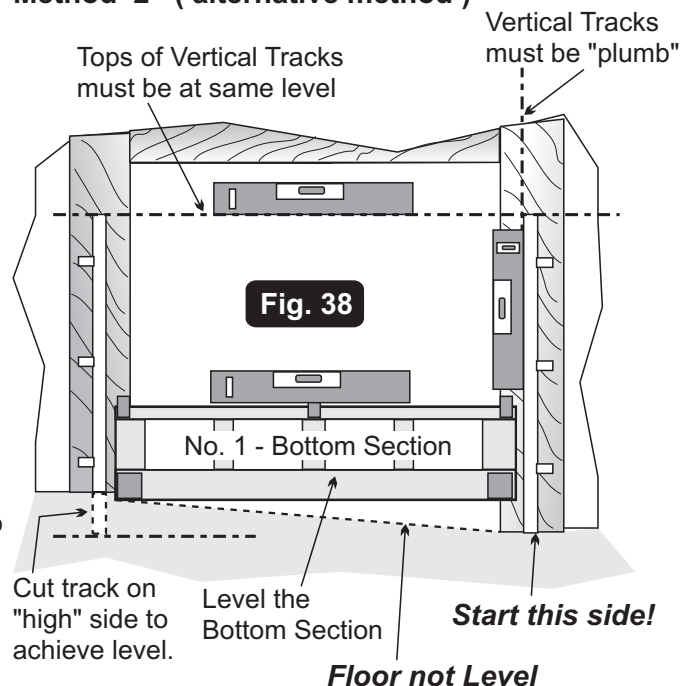
Level the Bottom Section

Set Vertical Track Level with opposite side track.

Floor not Level



#### Method 2 ( alternative method )



Cut track on "high" side to achieve level.

Level the Bottom Section

Start this side!

Floor not Level

## DOUBLE SECTIONAL DOOR INSTALLATION

### Step 1 Double Sectional Door Installation

The assembly of Double Size Sectional Doors is essentially the same as that for Single Size Doors, the main differences being that :-

- 1 There are more components, ( hinges etc. ), to fit to the door,
- 2 Usually, reinforcing struts, known as Top-Hat Bracing Struts, ( Fig 39 ), are required to strengthen the door sections, **and** .....
- 3 The spring system is usually of the "**torsion**" type. The assembly and installation of torsion spring systems is very different to the "**tension**" type systems.

**Follow Steps 1 to 15 of "Section 3" for the procedures relating to attachment of the hinges and other components to the door sections, assembly and installation of the tracks, erection of the door jambs, etc.**

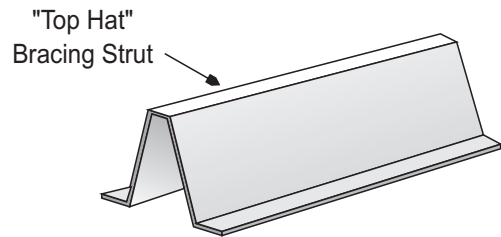


Fig. 39

### Step 2 "Top Hat" Bracing Struts

( See Fig 40 )

- 1 Top Hat Bracing Struts are recommended for **all** door sections **3000 mm** and longer.
- 2 For door sections over **4000mm** long, it is recommended to fit at least **one** strut per section as shown. Shorter sections may require only one strut every alternate section.
- 3 Screws should not be further than **400 mm** apart.

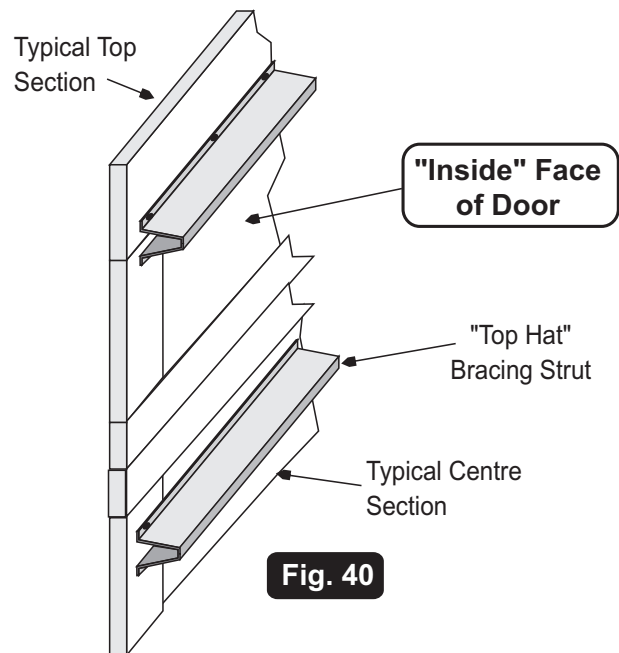


Fig. 40

### Step 3 Timber Jambs for "Torsion" Spring Systems

( See Figures 41, 42 & 44 )

- 1 A packing Block for the Centre Bearing is required. *This packing block must be the same thickness as the side jambs. This is to ensure that the Torsion Tube remains straight.*

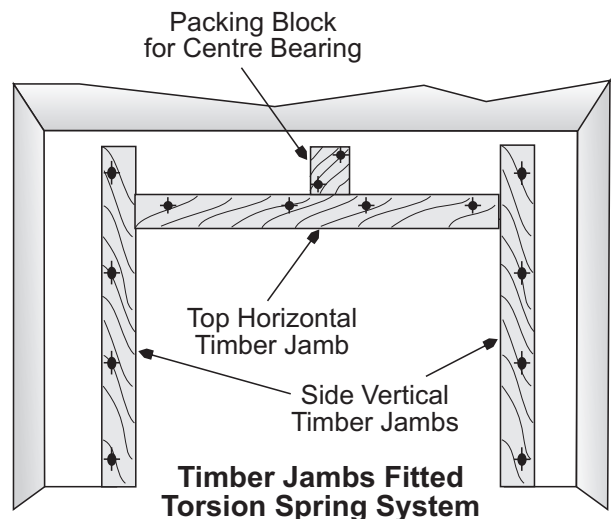
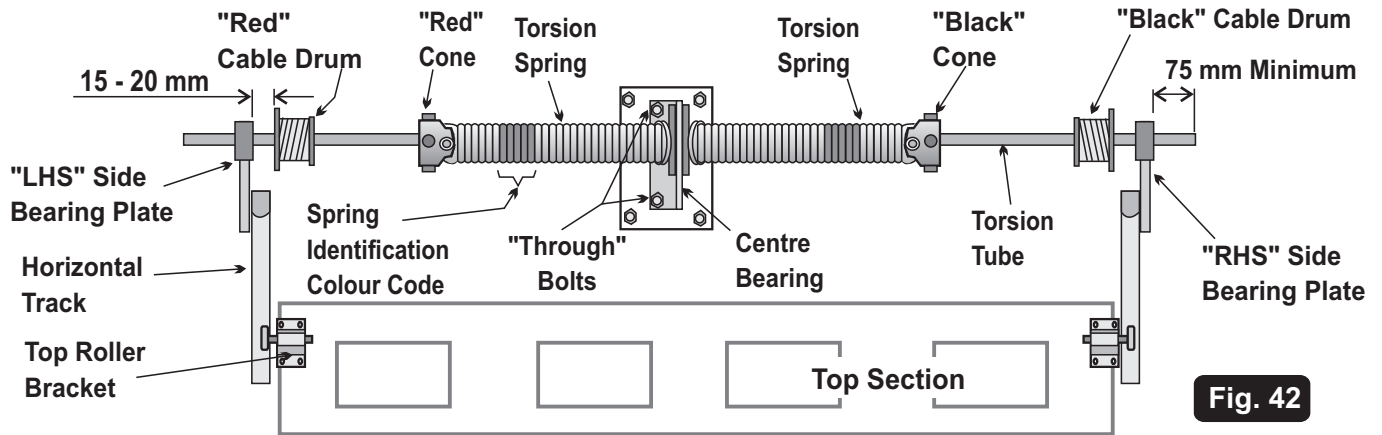


Fig. 41

## DOUBLE SECTIONAL DOOR INSTALLATION



**Fig. 42**

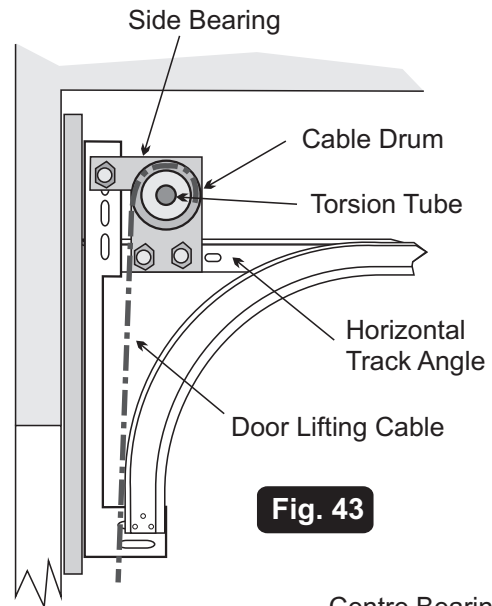
### Step 4 Assembling the "Torsion" Tube

- 1 Assemble the "Torsion" Tube on the floor.
- 2 Slide the Centre Bearing onto the tube up to the middle point.
- 3 Slide the Torsion Springs onto the tube with the "Stationary" Cones towards the Centre Bearing.
- 4 **Now ... !** Slide the two Cable Drums onto the tube with the **"Red"** Drum to the LHS and the **"Black"** Drum to the RHS of the Centre Bearing.
- 5 **Finally ... !** Slide the two Side Bearings onto the tube.

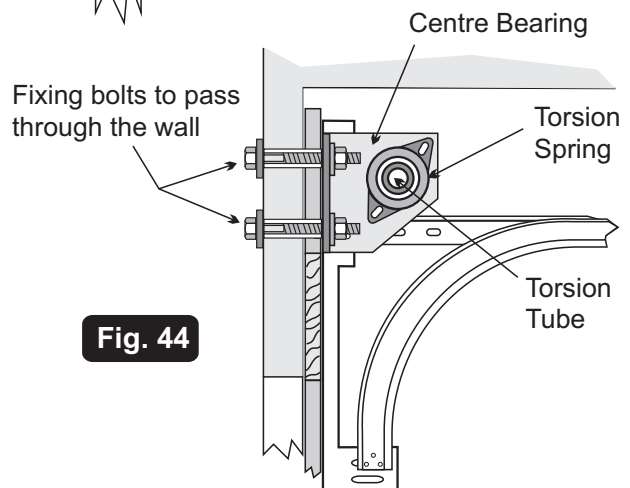
#### TAKE NOTE:-

- 1) The **"Red"** Winding cone is on the LHS of the Centre Bearing and the **"Black"** one to the RHS.
- 2) The Side Bearings are **"left"** and **"right"** handed !
- 3) **Do not fix anything in place just yet !**

- 6 Lift the assembly into place.
- 7 Bolt the Side Bearings to the Horizontal Track Angles as shown.
- 8 Position the Centre Bearing over the Packing Block.
- 9 Level the Torsion Tube and mark the positions for the fixing bolts for the Centre Bearing.
- 10 Drill **10 mm** holes **through the wall** and anchor the Centre Bearing with **long bolts**.



**Fig. 43**



**Fig. 44**

### IMPORTANT NOTES

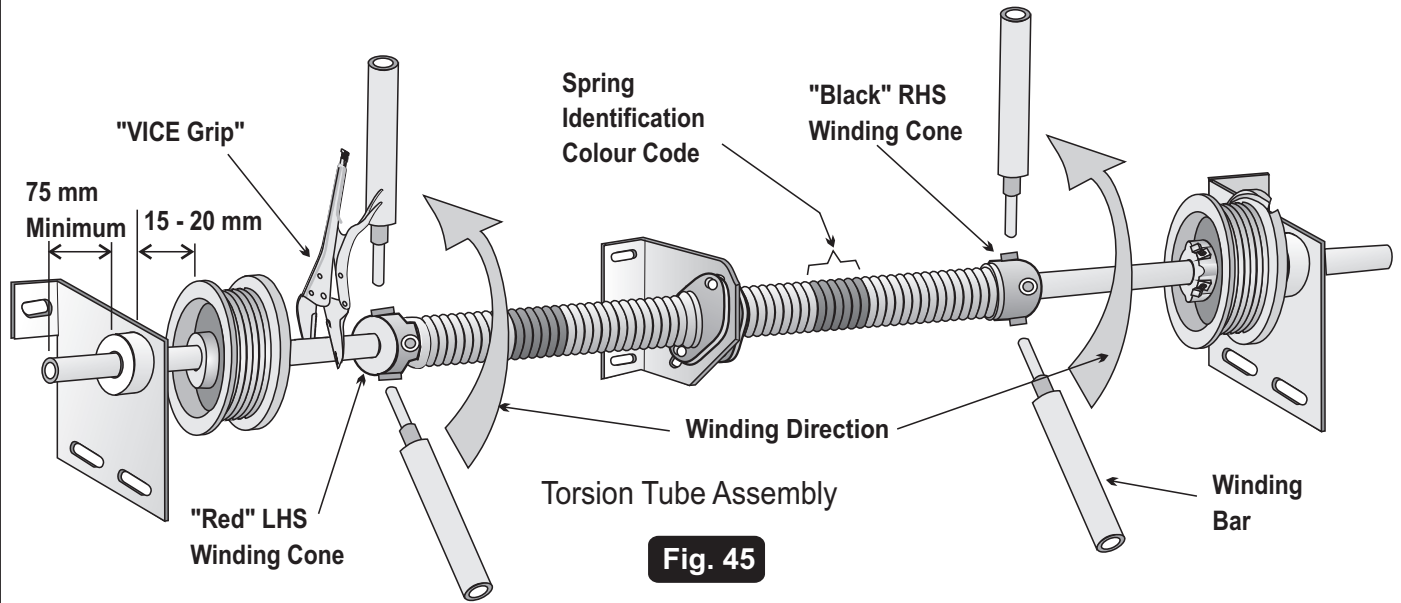
It is very important that the Centre Bearing is very secure. The Centre Bearing is restraining the total forces being applied by the springs.

If the Centre Bearing should come loose, the repercussions could be disastrous !!!

It is not sufficient to use plastic Wall Plugs as anchors for the fixing screws.

Use only long bolts through the structure to secure the Centre Bearing.

## DOUBLE SECTIONAL DOOR INSTALLATION



**Fig. 45**

### Step 5 .... continued

- 11 Be sure to allow the Torsion Tube to extend at least 75 mm beyond the Side Bearings at each end.
- 12 Attach the door Lifting Cables to the Cable Drums.
- 13 **Start with the LHS drum ... !** Position the Cable Drum +/- 20 mm from the Side Bearing and fasten it to the Torsion Tube using the Square Head Screws provided on the drum.
- 14 Rotate the Torsion Tube to take up the slack in the Lifting Cable. Use a pair of "VICE" Grips to prevent the Torsion Tube from turning.
- 15 **Go to the RHS drum ... !** Position the Cable Drum +/- 20 mm from it's Side Bearing. Rotate the drum to take up the slack in the Lifting Cable. Fasten the drum to the Torsion Tube.

### TAKE NOTE:-

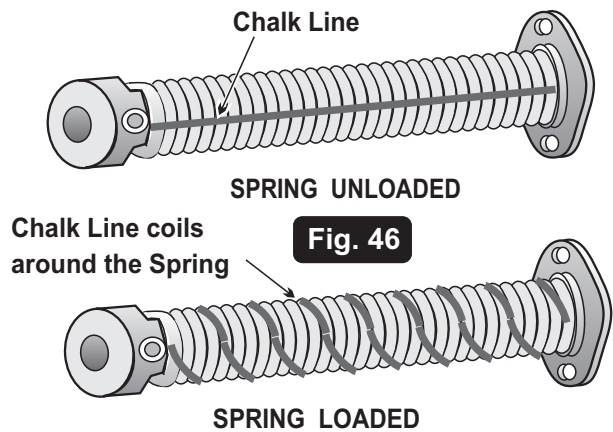
*It is very important to make sure that the Lifting Cables are of the same length and that both have an equal amount of tension in them when the drums are fixed to the Torsion Tube.*

### Step 6 Winding Up the Torsion Springs.

- 1) Before winding up the springs, make sure that all bearing plates are secure, **especially** the Centre Bearing.  
**The ladder used must be strong and stable !**  
**Do not use a box or chair to stand on ! Use a sturdy ladder. The stored energy in the spring is great and very serious injuries may be sustained if the incorrect procedures or inferior tools are used!**

### Step 6 ... continued.

- 2) It is recommended that the springs be given an initial wind and then unwound to allow the springs to **"settle in"**. The manufacturer's Spring Information Card should state the number of turns to be wound onto the spring.
- 3) Draw a straight chalk line along the length of the spring. This will assist you to count the number of turns being applied to the spring.
- 4) **Lubricate the spring !**



**Fig. 46**

### CAUTION ! CAUTION ! CAUTION !

**Take great care when winding the springs!**  
**Use only the correct type and size Winding Bars ! Two bars are required !**  
**Do not use Screw Drivers or other ill-fitting bars !**  
**Never stand directly behind or below the bars when winding the springs !**  
**Never! ..... Apply more turns to the spring than the manufacturer stipulates on the Spring Information Card.**

## SECTIONAL DOOR INSTALLATION TROUBLE SHOOTING GUIDE

### SYMPTOM 1

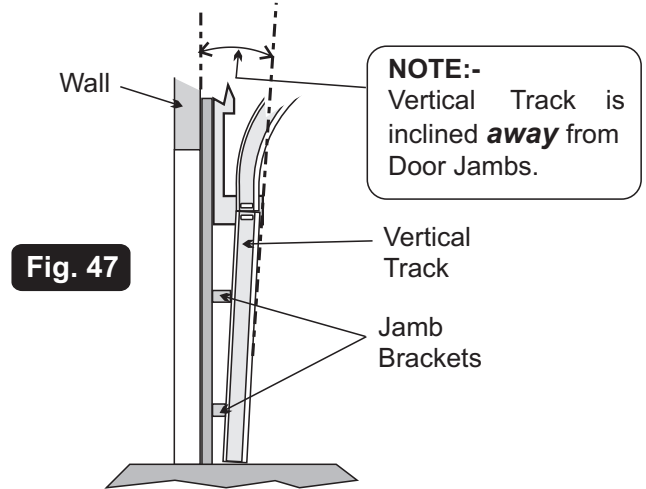
**Door is not well balanced ! ... Door is heavy to lift up from "closed" to "open" positions.**

### SOLUTIONS 1

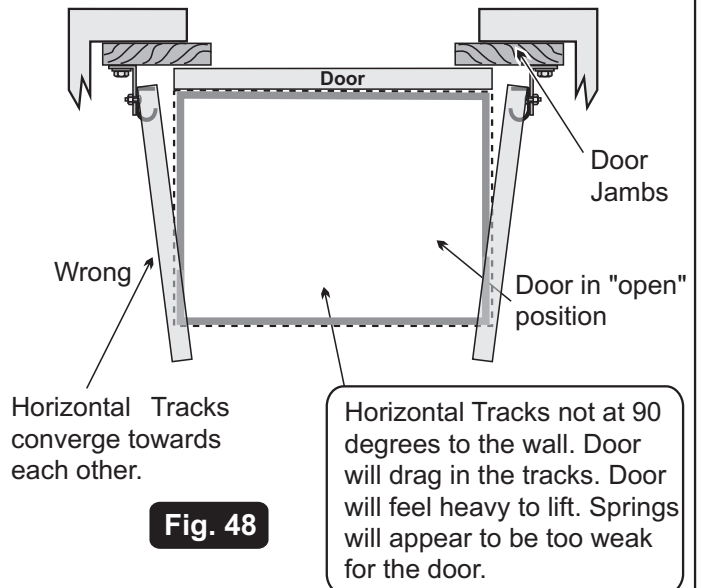
**Possible Causes / Check the following .....**

- 1 **Springs / Hardware components may be damaged.**  
Check for stretched or broken springs! As a general rule, springs for domestic doors have a "design life" of **10 000** cycles. This translates to an average lifespan of **4 - 5** years.  
**Replace all damaged components !**
- 2 **Spring has not been wound correct number of turns.**  
Check that the correct number of turns have been wound onto the spring( s ). See Spring Information Card.
- 3 **Spring is too "light" for the door.**  
*If* the number of turns is correct, then check that the correct size spring has been used ?
- 4 **Door is "wedged"**  
The door may be "**wedged**" between the track and the door jambs. The Vertical Track should be inclined at a slight angle **away** from the wall so as to allow the door to run freely. If the Vertical Track is not sufficiently inclined or, if the track is too close to the jambs ( wall ), the door could become wedged, (i.e. jammed ), thus causing the door to "**drag**" and feel **heavy**. ( See Step 13 )
- 5 **Tracks are mis-aligned.**  
Check that the Vertical Tracks are "plumb", ( i.e. vertical ), and the Horizontal Tracks are at **90** degrees to the wall.  
**The door may be "squeezed" - Vertically.**  
Check that the Vertical Tracks are not too close to the edge of the door. There should be **15 - 20mm** of clearance between the door and Vertical Track. ( See Steps 15 & 17 )  
**The door may be "squeezed" - Horizontally.**  
Check that the Horizontal Tracks are not converging towards each other, also causing the door to be "**squeezed**" as it opens. This will also cause the door to feel "**heavy**".
- 6 **Cable Drums may be jammed.**  
Check that the Cable Drums are turning "freely".
- 7 **Springs may be binding.**  
Check that the spring (s) is lubricated. If the coils are binding, a lot of extra drag is imposed creating the impression that the door is "**heavy**".
- 9 **Torsion Tube.**  
The Torsion Tube assembly may be out of level. This will cause extra friction in the system.

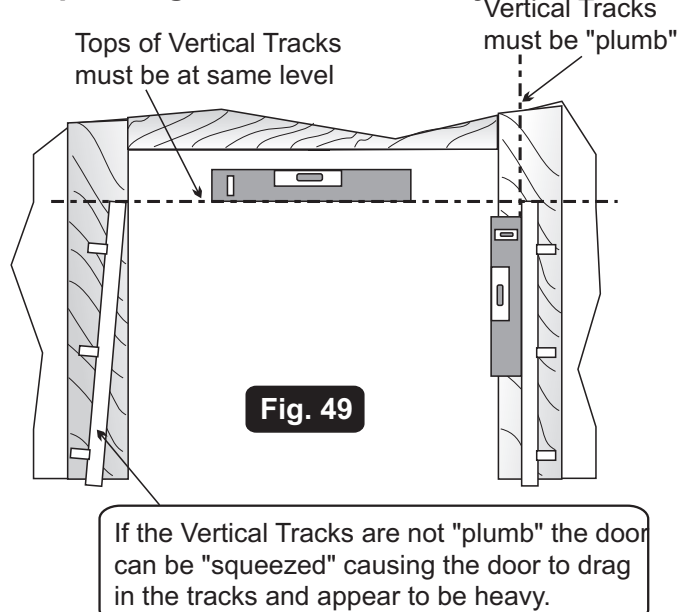
### "Wedging" of the Door



### "Squeezing" the Door Horizontally



### "Squeezing" the Door Vertically



## SECTIONAL DOOR INSTALLATION TROUBLE SHOOTING GUIDE

### SYMPTOM 2

**Door is not well balanced !**

*... Door is heavy to lift up from the "closed" position but gets "lighter" as the door is raised to the "open" position.*

### SOLUTIONS 2

*Possible causes / Check the following .....*

**1 Repeat all the checks as for SYMPTOM 1 above.**

**2 Horizontal Tracks may not be level.**

The Horizontal Tracks may be inclined "downwards". This causes too much weight to transfer to the Horizontal Tracks. If the tracks are "declined" to a downward angle, the door will tend to run very quickly to the "open" position. The spring design for normal domestic doors assumes that the weight of the door is gradually transferred from the "vertical" plane to the "horizontal".

**3 Spring Tension.**

The springs have been "over wound". There are too many turns on the spring ! This is an indication that the springs are too "light" for the door.

**Heavier springs are needed !!!**

### SYMPTOM 3

**Door is not well balanced !**

*... Door is easy to lift up from the "closed" position but gets "heavier" as the door is raised to the "open" position.*

### SOLUTIONS 3

*Possible causes / Check the following .....*

**1 Repeat all the checks as for SYMPTOM 1 above.**

**2 Horizontal Tracks may not be level.**

The Horizontal Tracks may be inclined "upwards". This causes too much weight to "hang" in the Lifting Cables. The spring design for normal domestic doors assumes that the weight of the door is gradually transferred from the "vertical" plane to the "horizontal". If the Horizontal Tracks are not level, the weight of the door will continue to remain in the cables giving the impression that the door is "heavy".

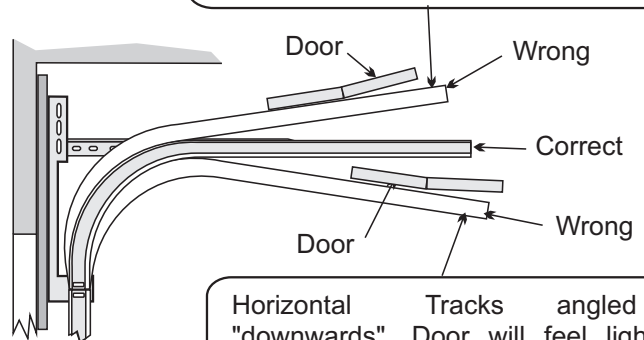
**3 Spring Tension.**

The springs have been "under wound". There are not enough turns on the spring ! This is an indication that the springs are too "heavy" for the door.

**Lighter springs are needed !!!**

### Horizontal Track Mis-aligned - Condition 1

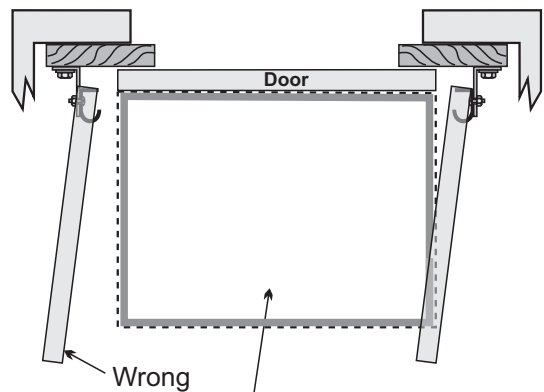
Horizontal Tracks angled "upwards". Door will feel heavy. Springs will appear to be too weak for the door.



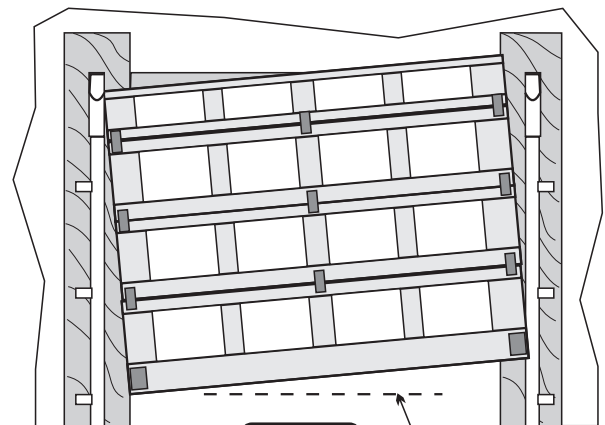
**Fig. 50**

Horizontal Tracks angled "downwards". Door will feel light. Springs will appear to be too strong for the door.

### Horizontal Track Mis-aligned - Condition 2



Horizontal Tracks not at 90 degrees to the wall. Door will try to take up the position shown causing it to drag in the tracks. Door will feel heavy to lift. Springs will appear to be too weak for the door.



**Fig. 52**

Door out of level.

## SECTIONAL DOOR INSTALLATION TROUBLE SHOOTING GUIDE

### SYMPTOM 4

**Door is out of level !**

*... Door does not close "level".*

*... Door is out of level when "open".*

### SOLUTIONS 4

*Possible causes / Check the following .....*

#### 1 Vertical Tracks

The tops of the Vertical Tracks are not level.

#### 2 Horizontal Tracks

The Horizontal Tracks are not at 90 degrees, (right angles), to the front wall ( door opening ).

#### 3 Lifting Cables

The Lifting Cables are not of the same length. Check also that the Cable Drums have not moved on the Torsion Tube.

***Lifting Cables may be stretched or broken !***

#### 4 Floor Level

The door sections were not "levelled" at the start of the installation.

### SYMPTOM 5

**Lifting Cables come off the Cable Drums / Pulley Wheels !**

*... As the Door is raised, the Lifting Cables become "slack" and come off the drums / pulleys.*

### SOLUTIONS 5

*Possible causes / Check the following .....*

#### 1 Springs are "under wound" or are "under tensioned."

This is an indication that the springs are too "heavy" for the door.

***Lighter springs must be used !!!***

#### 2 Door is being lifted too high.

Install door stops to prevent the door from being lifted too high.

#### 3 Cable Drums / Pulley Wheels may be damaged.

Replace the Cable Drums / Pulley Wheels. Worn drums and pulleys will damage the Lifting Ropes.

### SYMPTOM 6

**Hinges are binding and making noises.  
Hinges are tearing off the door.**

### SOLUTIONS 6

*Possible causes / Check the following .....*

#### 1 Track Radius is too small !

*As the Door is raised, the door sections creak and the hinges are jam-up.*

This is an indication that the door sections are too wide for the size of track radius being used.

***Use a larger track radius !***

#### 2 Door Sections are deflecting too much.

The door frame is too "soft". The door sections are not adequately braced and are sagging in the centre. Reduce the sag in the door by fitting Top-Hat Bracing Struts across the full width of the door. Each section should be braced.

#### 3 Centre Hinges.

There are not enough Centre Hinges fitted to the door !

## GENERAL SERVICING

*Check the following .....*

#### 1 Fasteners.

Check for loose fasteners. All screws, nuts and bolts etc., must be secure !

#### 2 Damaged Components.

Replace all damaged components.

#### 3 Replacing Springs.

Door springs are designed for a limited "life-span".

***Never replace only one spring in a multi spring system.***

***Always replace all the springs on a door !!!***

#### 4 Lubrication.

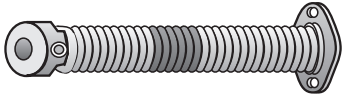
Lubricate all hinges, bearings and rollers regularly!

## DOOR HARDWARE SPARE PARTS

### Description



"TENSION" Springs  
Sectional Doors



"TORSION" Springs  
Sectional Doors

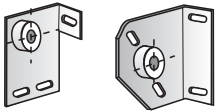


Hinges ( Light Duty )

Hinges ( Heavy Duty )

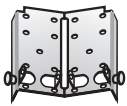


Top Roller Brackets

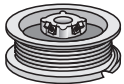


Bearing Plates - Side Type

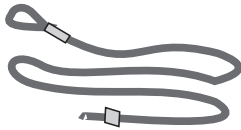
Bearing Plates - Centre Type



Bottom Corner Lifting Brackets



Cable Drums

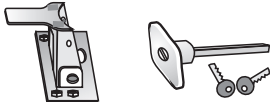


Cables - Lifting and Safety  
( Wire Ropes )

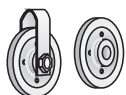


Chain.

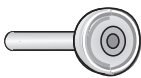
Hooks - "S" & "W" Types.



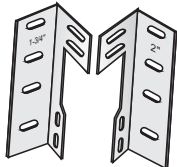
Latches, Handles and Locks



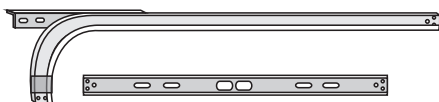
Pulley Wheels



Rollers

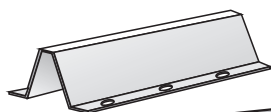


Track Header Brackets  
( Flag Brackets )



Horizontal Tracks

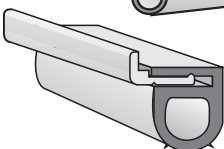
Vertical Tracks



"Top-Hat" Struts



Torsion Tubes.



Weather Sealers and Retainers.