

brano industries (pty) Ltd.



p.o. box 277, bramley, 2018, rep. of south africa.
tel +27 (011) 887-0625 fax +27 (011) 887-7616
e-mail:- sales@brano.co.za ; web:- www.brano.co.za

"pro-alpha 2000"

electric garage door operator

Installer's Instruction Manual for Automatic Domestic Garage Doors Manual MAN - 02 Version 3

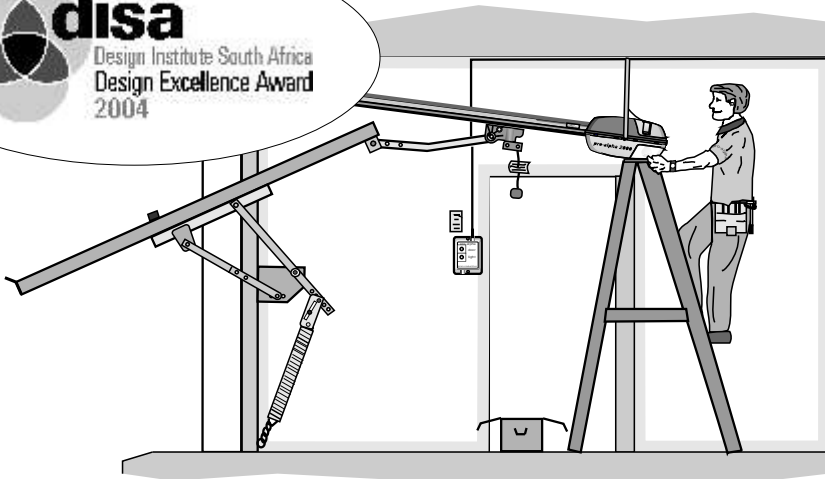
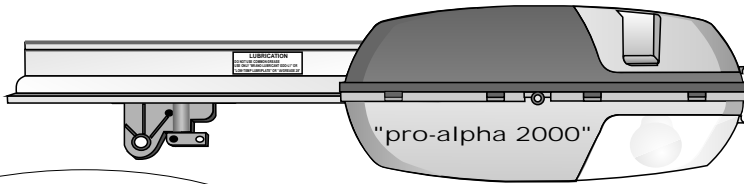

When in doubt

..... Read the Manual !!!

Dealers & Installers ! Read this section carefully !!!!

Legal Notices

Important Notes for Dealers and Installers Regarding the "Condition of Garage Doors and Door Operators"

- 1) As is the case with any installation of automatic garage door operators it is most important that the doors are in good condition and are working in accordance with the manufacturers specifications. In other words springs, lifting cables, pivot pins, pulleys, drums, hinges, in fact every component must be in good working order.
- 2) The balance of the doors is vitally important. Before installing an automatic door operator, test the door to make sure that it is properly balanced.
- 3) If the doors are not in a state of good repair, do not install an operator !
- 4) If, for any reason, you fit an operator to a door which is dysfunctional or is not in sound mechanical condition, or may be considered to be operating below the manufacturers specifications, and as a result thereof persons or property may be injured or damaged,

You ! ... the dealer / installer may be held responsible and liable !

- 5) The responsibility for ensuring that the doors are in a condition which is acceptable for the installation of automatic garage door operators remains solely with the dealer / installer. If the dealer and installer are not one and the same, the two may be held liable jointly and severably.
- 6) The law takes the view that you are the expert and therefore you should know best. You cannot have the client indemnify you against any damages. This would be contrary to the individuals "common-law rights". The law, now, is quite clear in this regard.
- 7) The best policy for all concerned and especially for dealers / installers is simply this:-

Fix the door before you automate it !!!

It's worthwhile doing, besides, it's good for business !

SABS - IEC Standard No. 60335 - 2 - 95

This standard specification is now published and it's impact is being felt far and wide in the door and gate industry. The most important aspect of this standard is that the minimum levels of safety for door and gate operators have been set down and all installations are required to conform to this standard. The responsibility for maintaining the standard is placed squarely on the shoulders of the installers / dealers, in much the same way as electricians are responsible for the work they do. DIY'ers take note !

If something goes wrong and someone is injured by an automatic garage door or gate and the cause is deemed to be due to inferior installation procedures or workmanship, or failure to observe the standards laid down, the blame will fall at the foot of the installer / dealer. The law assumes that if you install automatic operators to doors or gates, you, the installer / dealer are familiar with the requirements of this standard and will have satisfied yourself that the installation will comply with every aspect of the standard. Don't underestimate the seriousness of these standards or the consequences that may result from any transgression thereof.

Be warned !!! You do so at your own risk !!!

In order to assist dealers and installers Brano Industries, from time-to-time, arranges training courses covering the installation and maintenance of garage doors and door operators. Contact us for details of when these courses will be run. It will be the best investment you can make in your business and your future.

"brano door operator installation manual"

INDEX

"pro-alpha 2000" Installer's Manual



| Section No. | Page No. | Description |
|-------------|----------|--|
| | 00 | Legal Notices |
| | 01 | Index |
| | 01 | "brano" Distribution Centres |
| 1 | 02-03 | Suitable Types of Doors |
| 1 | 04 | Doors Not Suitable for Automation |
| 1 | 05 | Unsafe Installation Practices |
| 2 | 06 | Door Operator Terminology and Technical Specifications |
| 3 | 07-08 | Pre-installation Preparations |
| 4 | | Sectional GDO Installation |
| 4.1 | 09-10 | "Working Space" Tables |
| 4.2 | 10-13 | Installation Procedures Problem Installations - Low Headroom |
| 5 | | Tip-Up GDO Installation |
| | 14 | "Working Space" Tables |
| | 15 | Installation Procedures |
| | 16 | Problem Installations - "Low Headroom" |
| | 17 | Single Access Garages |
| 6 | 18 | PC Board Connections |
| | 19 | Electrical Connections |
| | 20 | Safety Beam Connections |
| 7 | | Setting-up Instructions |
| | 21 | Travel Limit Switches |
| | 22 | Overload Sensor Adjustments |
| 8 | 23 | Operator Functions |
| | 23 | Testing and Commissioning |
| | 24 | Information Labels and "Handing Over" |
| 9 | 25 | Servicing and Maintenance Lubrication Wearing Parts |
| 10 | 26-27 | "pro-alpha 2000" Spare Parts |
| 11 | 28-31 | Trouble Shooting Guide |
| 12 | 32-33 | Terms and Conditions of Warranty |
| Back Cover | | Door Operator Equipment Details and Service Record. |

Dear Installer,

Thank you for choosing the "pro-alpha 2000" garage door operator for your installation.

The "pro-alpha 2000" incorporates the very latest features associated with this type of equipment and complies with SABS - IEC 60335 - 2 - 95 and equivalent US, European, British and Australian standards.

Only the very best materials have been used in the manufacture of the machine. Extensive and punishing testing of the door operator has given us the confidence to offer a 3 year Extended Warranty on the unit subject to the terms and conditions contained herein.

We trust that you will find the "pro-alpha 2000" to be everything you could want in a garage door operator and a profitable one to work with.

If you have any queries or simply would like to tell us of your experiences with the "pro-alpha 2000", please contact us.

Yours sincerely,

brano industries (pty) ltd.

July 1999 / October 2001 / February 2004

Johannesburg brano industries (pty) Ltd.
Head Office:- 22 - 3rd Street, Wynberg, Sandton, RSA
and Factory PO Box 277, Bramley, 2018, RSA.
Tel (+27) 011- 887- 0625/6/7/8
Fax (+27) 011- 887- 7616

Cape Town brano cape (pty) ltd
Unit 3, EXPO Centre, Koeberg Rd, (Deliveries 35 Stella
Road), Montague Gardens, Cape Town.
Tel 021- 552- 5350 Fax 021- 552- 5350

Pretoria brano pretoria (pty) ltd
Unit 8 - Block "B", Scientia Techno Park,
Meiring Naude Str., CSIR, Pretoria,
Tel 012- 349- 1494 Fax 012- 349- 2963

Westrand brano westrand cc
Shop No 2 Ontdekkers Centre, cor Louis Str. &
Ontdekkers Rd, Roodepoort,
Tel 011- 760- 5773/3884 Fax 011- 760- 5774

Bloemfontein brano free state (pty) ltd
17 MacKenzie Road, East End, Bloemfontein.
Tel 051- 447- 2850 Fax 011- 447- 7095

1.1 INTRODUCTION

First it is necessary to identify the type of door that is to be automated. The most common types of domestic garage doors are:-

- 1.1.1 Sectional Overhead Doors.
- 1.1.2 One Piece "Tip-Up" Doors with Jamb Mounted Door Hardware, (trackless type).
- 1.1.3 One Piece "Tip-Up" type Doors (with "overhead track").
- 1.1.4 One Piece "Pivot" type Tip-Up Doors, (trackless type doors).
- 1.1.5 One Piece "Tip-Up" Counterweight Balanced type Doors, (vertically tracked type doors).
- 1.1.6 Steel Roll-Up type Doors, (flexible curtain type doors).

Take Note:-

"Vertically" tracked Tip-Up doors, (e.g. Counterweight" Balanced types), and "Steel Roll-Up" type doors both require the assistance of special "adaptor" kits in order to be automated. Consult your dealer for advice.

Refer to the specific instructions for the type of door you wish to automate.

1.2 Inspection Of The Door

Inspect the garage door for signs of damage or worn or faulty components.

Repair the door as necessary !

Take Note:-

It is very important that the door be in a state of good repair and in proper working order.

Do not automate a door that is not in good working order. Should persons be injured or property be damaged by a door that is considered to be in a condition that is below the specifications of the manufacturer, then you, the installer / dealer may be held jointly and severably responsible and liable.

1.3 Door Type 1
SECTIONAL TYPE DOORS

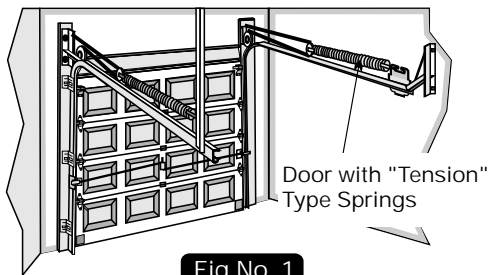

Fig No. 1

Door with "Torsion" Type Springs

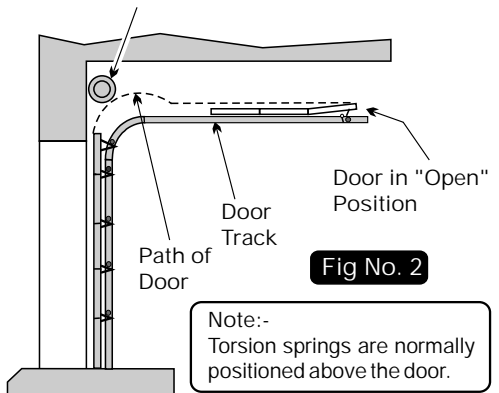

Fig No. 2

Note:-
Torsion springs are normally positioned above the door.

1.4 Door Type 2
"ONE-PIECE" TIP-UP TYPE DOORS

1.4.1 "Trackless" Type Tip-up Door
With "Pantograph" Mechanism

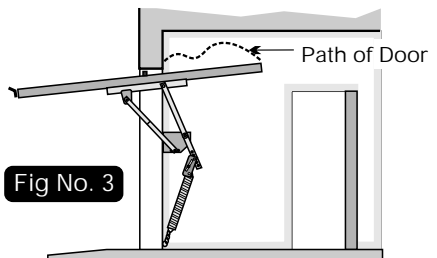

Fig No. 3

"SPRING BALANCED" TIP-UP DOOR

1.4.2 "Trackless" Type Tip-up Door With "Horizontal Pivot"

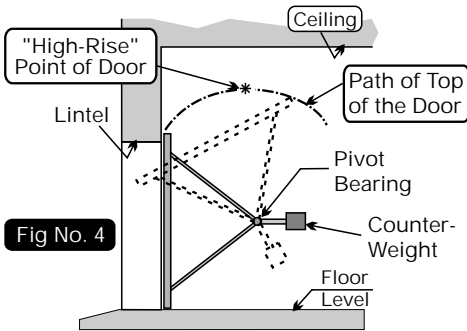

Fig No. 4

COUNTER-WEIGHT BALANCED "PIVOT" TYPE DOORS

1.5 Door Type 3
"ANGLED TRACK" TIP-UP TYPE DOORS

1.5.1 "Inclined Track" Tip-up Door With "Pantograph" Mechanism

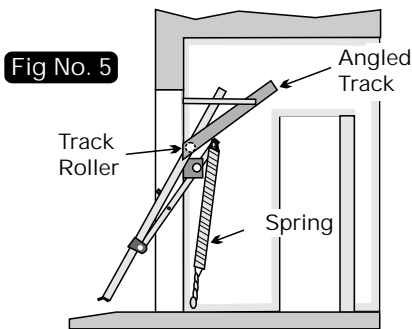

Fig No. 5

1.5.2 Door Type 4
"VERTICAL TRACK" TIP-UP TYPE DOORS

Read note 1.5.2.1

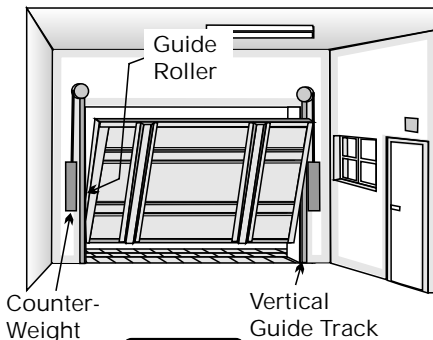

Fig No. 6

1.5.2.1 VERY IMPORTANT NOTE :-

This type of door can only be automated with the aid of a special adaptor system, viz., the "Vertical Track Adaptor Kit". When fitted with a "VTAK" system, the "built-in" overload sensors of the door operator, regardless of make or model, may be compromised to the extent that local safety standards may not be complied with. SABS-IEC Safety Standards preclude the use of this system for the automation of domestic garage doors. Check with your local operator dealer for more information.

1.6 Door Type 5
"ROLL-UP" TYPE DOORS

Steel "Roll-Up" Type Door

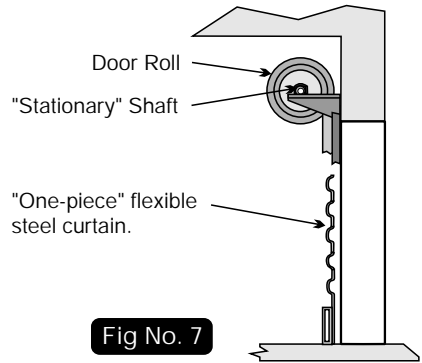

Fig No. 7

IMPORTANT NOTES ON THE CONDITION OF GARAGE DOORS

No door should be converted to automatic operation unless it is in good working order.

Before installing an automatic door operator, inspect the door for signs of worn, damaged or missing parts and repair or replace as necessary. Test the operation of the door to make sure that it is properly balanced.

Pay particular attention to the springs. Domestic garage door springs should be replaced after every 10 000 operating cycles, (or approximately 4 to 5 years of normal usage).

Read this section carefully !

For reasons of safety, certain doors should not be automated. One door in particular fails to comply with the safety standards set out in SABS/IEC 60335-2-95

This door is commonly referred to as a "Tip-In" or "Cam-Spring" type door.

Do not automate this type of garage door!

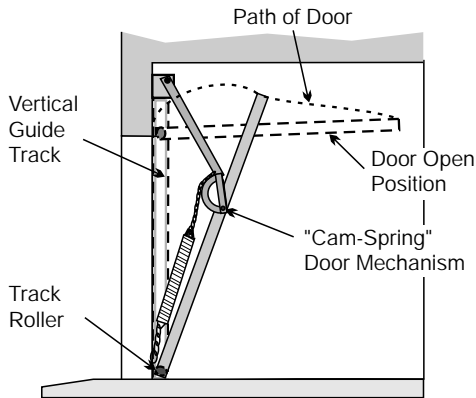

Fig No. 8

"Tip-In" or "Cam-Spring" Type Garage Doors

DISTINGUISHING FEATURES

A "one-piece" type door which has a "vertical" guide track. The distinguishing feature of the door is the placement of the Guide Roller.

The Guide Roller is positioned at, or close to, the bottom-most corner of the door panel. The effect of this arrangement is that it causes the door to open completely to the inside of the garage.

At no stage during the opening or closing cycle does any part of the door pass through or protrude from the opening.

When the door is fully open, the entire door remains completely inside of the garage.

These doors were intended for use in openings that have rounded or "arched" shapes and were sold as a cheaper alternative to Sectional type doors.

Typical openings in which "Tip-In" type doors are found.

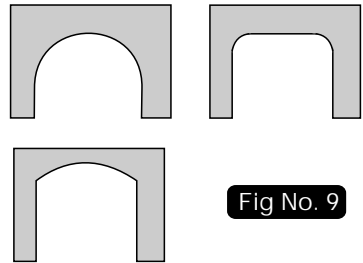

Fig No. 9

CAUTION! CAUTION! CAUTION!

These doors are unsafe for automatic operation as the force applied by the door operator is magnified as much as 40 times under the door due to the action of the door mechanism. The operator is unable to sense reliably obstructions in the path of the door.

IMPORTANT NOTE:-

These doors are classified as "Vertically Tracked" type doors.

All warranties, whether stated or implied, shall, "ipso facto", be rendered null and void if "Brano" products are fitted to such types of doors.

Unsafe Installation Practices

Do Not Install Door Operators In This Way



Single Door Operator Centrally Mounted Between Two "One-Piece Tip-Up Doors Which Are Rigidly Coupled Together.

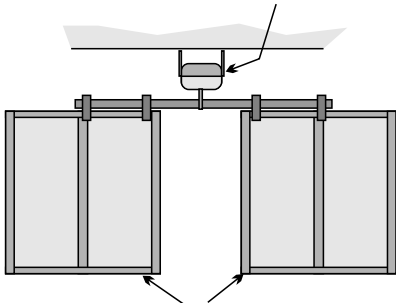

Two "One-piece" Tip-Up Doors Shown.

Fig No. 10

Single Door Operator Centrally Mounted Between Two Sectional Doors Which Are Rigidly Coupled Together.

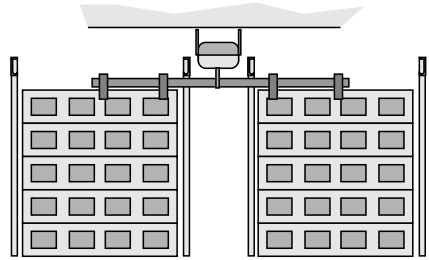

Fig No. 11

SABS - IEC 60335-Part 2 - 1995 sets down certain safety standards for the automation of garage doors. When two Tip-Up type doors are coupled together in the way shown above, the built-in "overload" sensors of the door operator, regardless of make and type, may be severely compromised to the extent that they may not respond quickly enough, if at all, to any obstructions in the path of the door.

Should any door which is automated in this manner cause an injury, or worse, to any person or damage to property, both the owner and the installer may be held jointly and severably responsible and liable and may suffer the consequences thereof.

Homeowners are advised to reject such installations lest they be incriminated in any claims.

The installation of door operators in this manner will render all warranties, wether stated or implied, null and void !

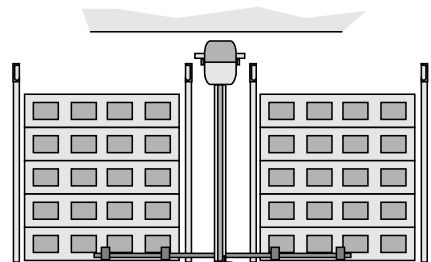

Two Sectional Doors With A Vertically Mounted Motor between the doors. (Similar to "side-mount" system used for Steel Roll-Up Doors)

Fig No. 12

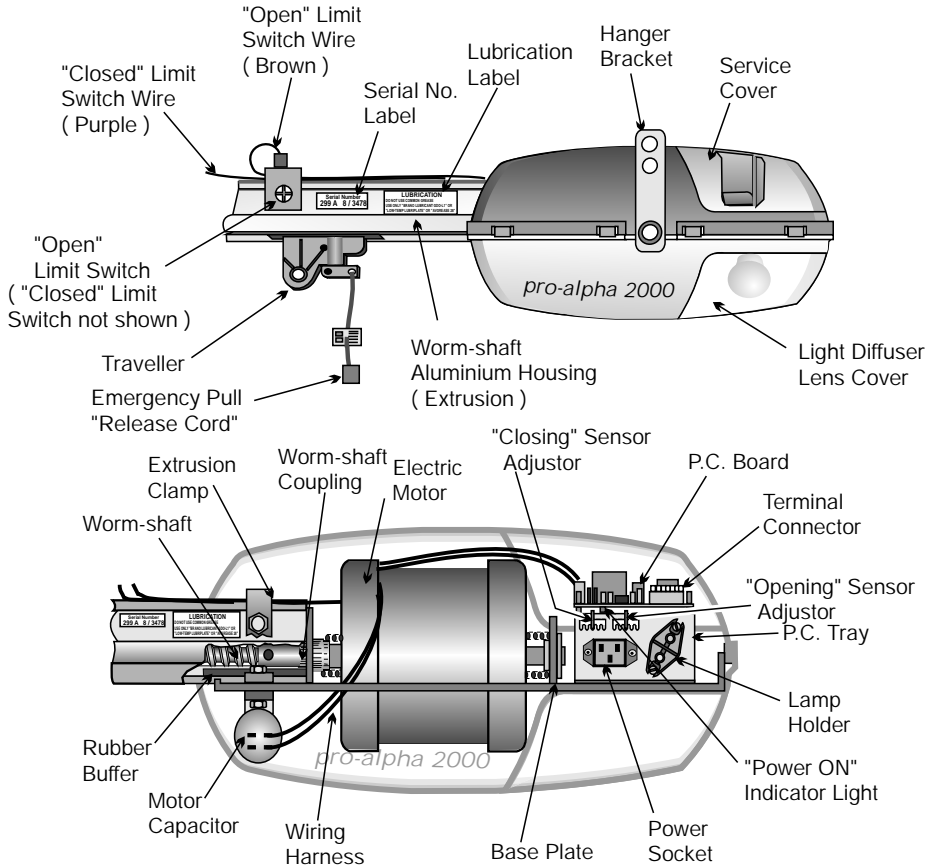

Fig No. 13

GENERAL DESCRIPTION

Electrically operated automatic garage door operator for use on domestic type garage doors.

MAINFRAME AND COVERS

Galvanized steel frame supports the motor and worm-screw housing. Moulded plastic cover encloses motor and electronic control board.

WORM-SCREW AND ALUMINIUM HOUSING

One piece worm directly coupled to the motor.
 One piece aluminium housing.

ELECTRIC MOTOR

- * Enclosed, fan-cooled, reversible type.
- * "Sealed for Life" Ball Bearings.
- * Single phase - 250 W - 50 Hz - 1450 rpm - 3,5 A

POWER SUPPLY

- * 220 V - single phase - 50 Hz

LIGHT

- * One lamp 100 W maximum output.
- * Type BC - (Bayonet base).
- * Automatic courtesy light timer +/- 3 minutes.
- * Light can be switched "ON" from the wall pushbutton.

3.1 RECOMMENDED TOOLS

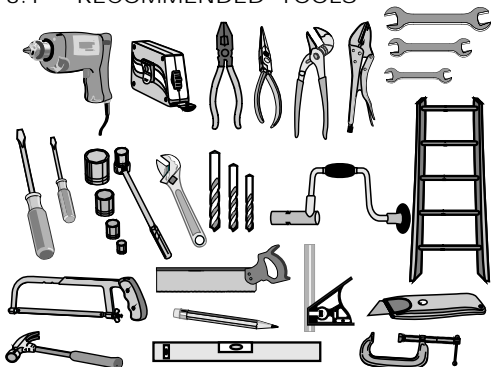

Fig. 14

The tools required to successfully complete the installation will depend to some extent on the type door to be automated, i.e. is the door constructed of Steel, Wood, Aluminium, Glass-fibre, or other material? The more comprehensive the range of tools available, the easier the job will be !!! Shown above is the range of hand tools we recommend you should have.

3.3 INSTALLATION PREPARATIONS

On receipt of the Door Operator, inspect the package for any signs of shipping damage. If damage is found, return the operator, complete with all accessories to your supplier.

Inside the package is a "packing slip". Stamped on the slip will be a QC number, (Quality Control number). Return this slip, or fax it directly to your local agent with your complaint.

Be sure to include the Serial number of the operator !

3.4 Check the contents of the package against the "packing slip" to make sure it is complete. This package contains all the hardware required to install the operator onto a "standard" domestic garage door. Also included are the Wall Push-button Console, Kettle Plug Connector, "Safety" and "Operation" information labels. If the door or the garage itself does not conform to standard specifications, special equipment may be required. Contact your nearest agent / dealer for advice.

The following items are not included in the standard operator hardware kit :-

- a 3 Pin - 15 Amp plug top,
- light bulb, (lamp)
- the electrical power supply cable,

- Special adaptor or accessory kits
- the Remote Controls. The remote controls are not supplied as part of the basic operator kit but are sold as optional extras as the type and specifications of the remote controls will vary from one installation to another.

3.5 Ensure that you have the necessary tools to complete the job. You are now ready to install the door operator.

Turn to Sections 4 & 5 "Sectional" and "Tip-Up Door Operator Installation Procedures"

NOTE:-

"pro-alpha" Series 1 Door Operators

The installation techniques and especially the electrical connections and setup procedures for the Series 1 "pro-alpha" Door Operators is different to those for the "pro-alpha 2000" and "Aladdin" machines.

Refer to the specific instructions for the "pro-alpha" Series 1 range of Door Operators.

3.6 Important Notes for Installers!

Always inspect the door first before committing to an installation !

Carefully inspect every component of the garage door for signs of wear or damage. Be particularly vigilant for missing parts !

Check for

- stretched or broken Springs,
- frayed or broken Lifting Cables, (wire ropes),
- worn rollers, pivot pins and sheave wheels,
- damaged Hinges,
- damaged Torsion Tubes and Support Bearings,
- Cable Drums,
- damaged Lifting and Steering Arms,
- damaged or missing Stoppers,
- damaged or missing internal Locking Devices,
- loose or missing nuts, bolts and screws.

..... and repair or replace as necessary !

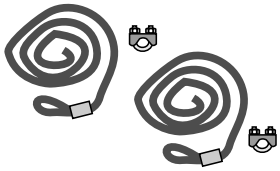
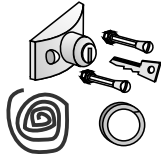
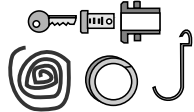
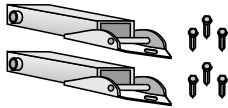
| | Description | Product Code |
|--|--|-------------------|
| <p>3.6.4 Very Important</p> <p>If the door is balanced by means of tension type springs, make sure the Safety Cables are securely anchored. If none are fitted to the door, insist that these be fitted before the operator is commissioned.</p> |  <p>"Spring Safety Cables" for Tension Spring Systems.</p> | 4 CABLE -SAFETY 1 |
| <p>3.7 Locking Devices</p> <p>It is necessary to render the locking devices inoperative for normal automatic operation, but do not remove them entirely.</p> <p>In the event of a malfunction of the door operator, it is essential that the door may still be secured.</p> <p>The best way to do this is to pin the Lock Cables or chains back with a screw or nail in such a way that the Lock Catches are in the "open" or "unlatched" position.</p> |  <p>Emergency Key Release Kit for Sectional and Tip-Up Doors</p> | 1 KEYS |
| <p>3.8 Garages Without Secondary Access Doors</p> <p>If there is no other means of access into the garage except through the main garage doors themselves, it is necessary to install an "Emergency Key-release" Kit for the door operator.</p> <p>It is also necessary to fit a normal outside "T" Handle Lock to the door. In the event of a malfunction of the operator system, the only way to secure the door will be from the outside by means of the "T" handle Lock !</p> |  <p>Emergency Key Release Kit for Steel Roll-Up Doors "Pro-Rola" System</p> | 1 KEYPR |
| <p>3.9 Special Accessories</p> <p>Some doors may require the installation of special equipment such as Low-Headroom Brackets in order to allow the door to work.</p> <p>Consult your " pro-alpha 2000" dealer for advice!</p> |  <p>Low-Headroom Bracket for Automatic Sectional Doors</p> | 1 KLHD - A |

4.1 Operator "Working Space"

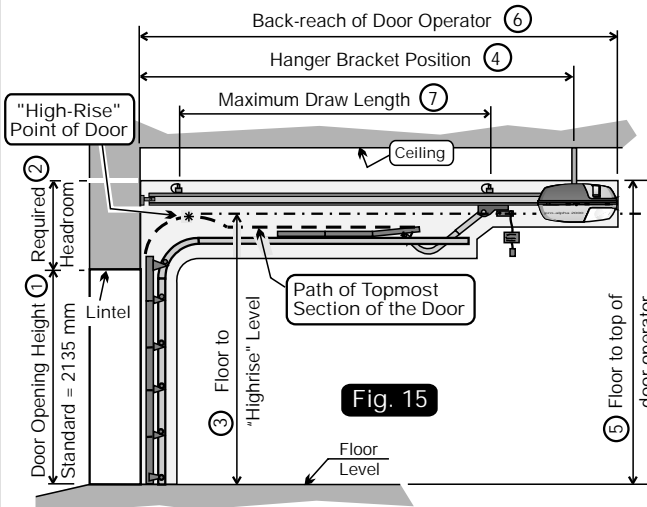

Fig. 15

High-lighted Row Refers to a Standard Height 5 Section Door
(All dimensions in mm)

| Opening Height (1) | No. of Sections | Track Radius | Headroom Required (2) | Highrise Level (3) | Hanger Bracket (4) | Top of GDO (5) | Back-reach GDO (6) | Draw Length (7) |
|--------------------|-----------------|--------------|-----------------------|--------------------|--------------------|----------------|--------------------|-----------------|
| 2135 | 6 | 254 (10") | 315 | 2380 | 2920 | 2445 | 3100 | 2350 |
| 2135 | 5 | 305 (12") | 360 | 2420 | 2920 | 2500 | 3100 | 2350 |
| 2135 | 4 | 380 (15") | 440 | 2500 | 2920 | 2575 | 3100 | 2350 |
| 2550 | 6 | 305 (12") | 360 | 2840 | 3620 | 2910 | 3800 | 3160 |
| 2630 | 5 | 380 (15") | 440 | 2925 | 3620 | 3070 | 3800 | 3160 |

Important Notes:-

The following table shows the minimum amount of "Working Space" that is required for the normal installation of standard size Sectional doors. If the space available is less than that stated here, then special equipment may be required to undertake the installation.

Certain assumptions have been made, i.e.:-

- 1) The opening heights are 2135 mm for standard doors or 2540 mm for caravan height doors.
- 2) The structure is level, square, plumb and true as the case may be.
- 3) For Sectional Doors, the door panel overlaps the opening by no more than 30 mm at the top and sides.

Contact your local dealer for advice before committing yourself to a difficult installation!

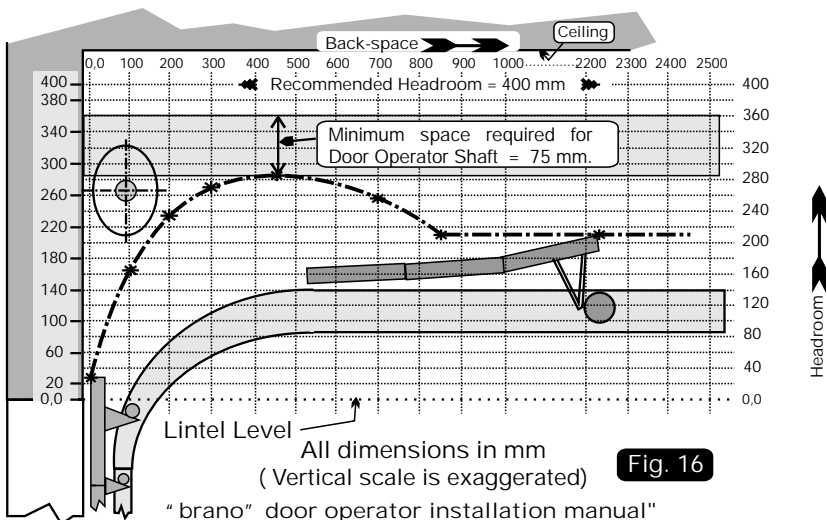

Fig. 16

4.2 Operator "Working Space"

Applicable to All Sectional Doors!!!
Irrespective of the type or size of the door that is to be automated, it is absolutely essential to have adequate "Working Space" for the equipment to operate in.

The most important dimensions to consider are:-

- 1) Available Backspace
- 2) Available Headroom
- 3) Floor-to-"High rise" point
- 4) Floor-to-Top of Operator

In other words

..... the Operator "Working Space" !!!

These 4 factors will determine the performance and functionality of the finished product !

Other useful information is included for installation purposes. Refer to the relevant sections of this manual.

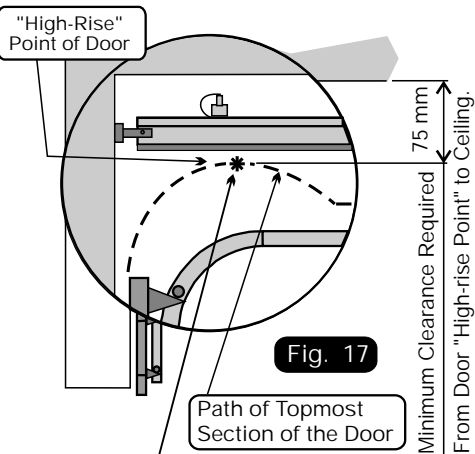

Fig. 17

Sectional Doors
Operator - to - Door Clearance at "highrise point" approx. 20 mm

4.3 Mounting the "Wall Header Anchor Bracket"

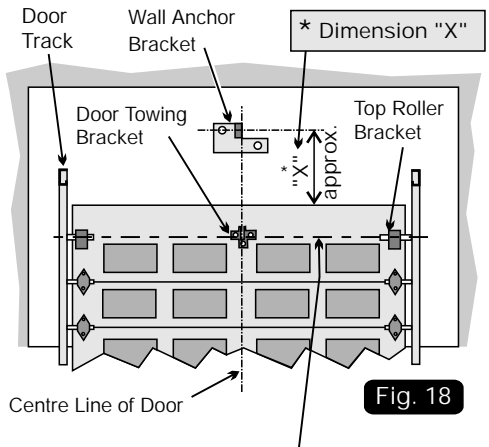

Fig. 18

Door Towing Bracket and Top Roller Bracket must be approximately in line with each other.

View of Door From Inside

Header Bracket Position
Dimension " X "
(approximate value)

| Track Radius | Horizontal Track Colour | Dimension " X " (approx) |
|--------------|-------------------------|--------------------------|
| 250 mm | Orange | 300 mm |
| 305 mm | Green | 360 mm |
| 380 mm | Blue | 430 mm |

- 4.3.1 First Establish the centre-point of the door. Mark-off the centre point along the top rail.
- 4.3.2 Next Draw a vertical line on the wall above the door at the centre-point position.
- 4.3.3 Then Slowly raise the door taking note of the highest position reached by the door as it moves to the "full-open" position.

Note:- Sectional Doors rise above their "closed" positions as they open.

- 4.3.4 Measure the height above the floor of the "high-rise point" of the door. This measurement is necessary in order to establish the position of the Header Anchor Bracket.
- 4.3.5 Make a mark on the wall corresponding to the "high-rise point" of the door. The Header Anchor Bracket is fixed above this mark.
- 4.3.6 Position the Header Anchor Bracket, on the wall in such a way that the right angle face of the bracket coincides with the centre-line mark of the door.
- 4.3.7 Mark the positions for the fixing screws and drill 10 mm dia. holes approximately 100 mm deep. Insert the 2 "Green" plastic wall plugs into the holes and fix the Header Anchor Bracket in place using the two M 8 x 90 mm Hex-head Washer-faced Lag Screws supplied.

Note:-

It is very important that the Header Anchor Bracket is well secured as this fixture takes all the forces acting in the system.

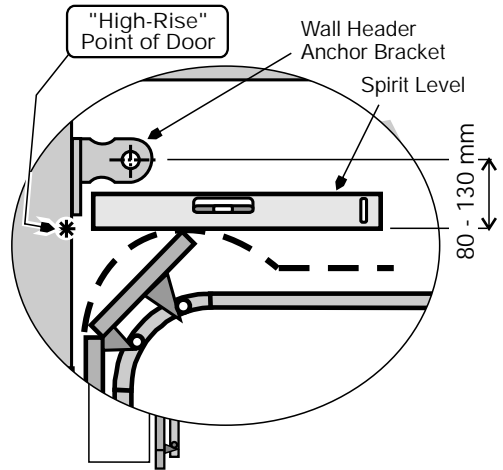

Fig. 19

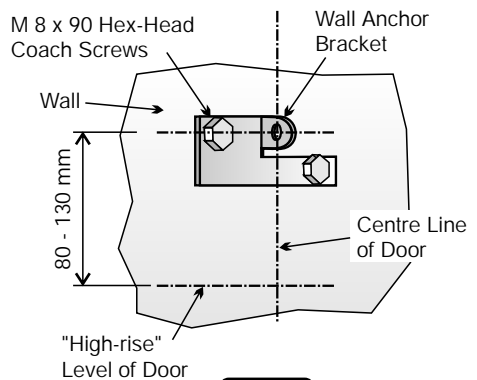

Fig. 20

4.4 Mounting the "pro-alpha" Garage Door Operator.

4.4.1 For all overhead type garage doors, the operator is suspended from the ceiling of the garage by means of 2 lengths of Punched Angle which are attached to the Hanger Brackets fixed to the Power-Head.

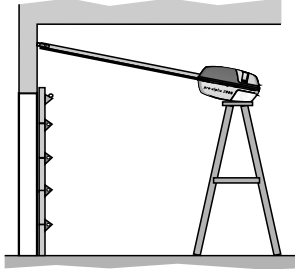

Fig. 21

4.4.2 First Attach the Aluminium Extrusion of the operator to the Header Anchor Bracket using the M 8 x 25 Hex-head Set Screw supplied.

4.4.3 Next Temporarily support the Power-head from the ceiling by means of a suitable rope or prop it up with a ladder as shown in Fig. 21

4.4.4 Then Open the garage door fully. This will assist you to position the operator on the "centreline" of the door.

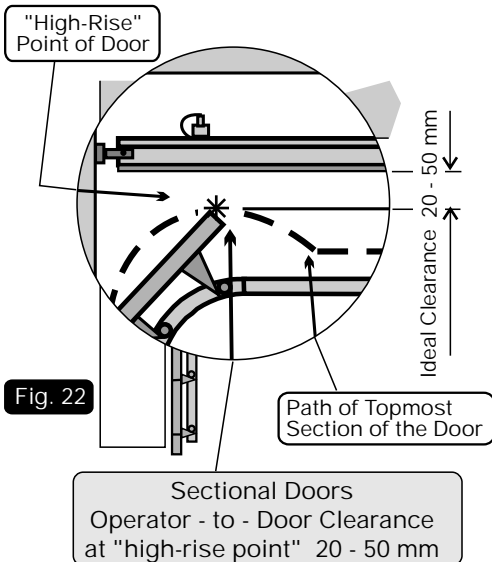

Fig. 22

4.5 Useful Dimensions

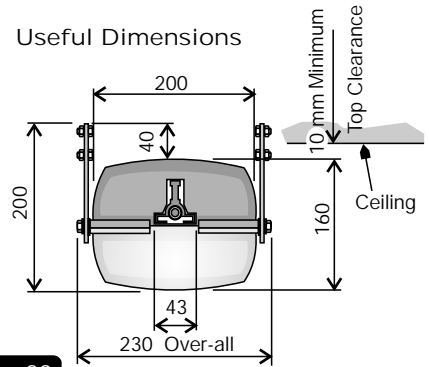
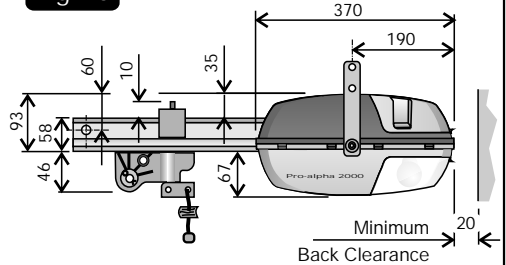

Fig. 23



4.5.1 Mounting the Power-head

4.5.2 Establish the position of the nearest roof beams or other suitable overhead structures from which the operator may be supported. Using the lengths of Punched Angle and Fasteners supplied, suspend the operator from the ceiling.

4.5.3 Take care to ensure the operator is positioned along the extended centreline of the door.

Note:-

For all Overhead Track type doors, the operator is mounted in such a way that it is "horizontal", i.e. "parallel" to the floor.

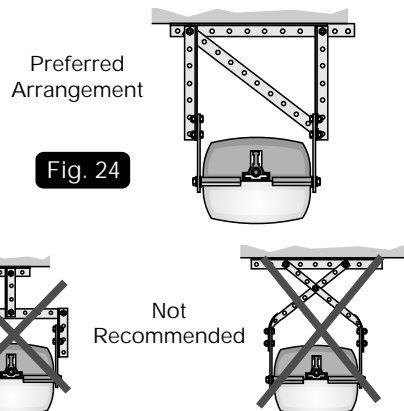

4.6 Restricted Headroom Installations

The Hanger Brackets are designed to be readily adaptable for "low-headroom" installations. Make a 90 degree bend in the Hanger Bracket through the centre of the lower of the two holes as shown. The bracket may then be fastened directly to the ceiling. The clearance between the ceiling and the operator will be sufficient to allow the removal of the operator's Service Cover.

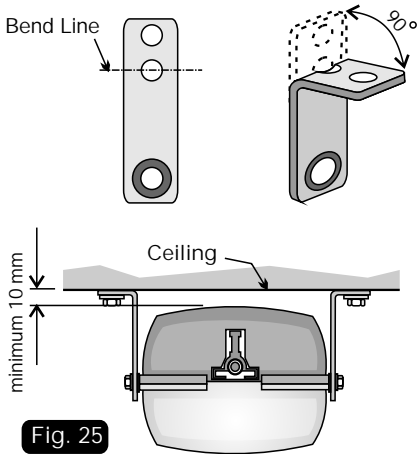

Fig. 25

4.7 Attaching the Door Bracket - Sectional type Doors

4.7.1 The Door Bracket is attached to the door at the centreline position in such a way that the Clevis Pin in the Door Bracket is approximately in line with the topmost Rollers of the door.

4.7.2 Use the three No 12 x 30 mm slotted pan-head head screws provided to fix the Door Bracket to the door.

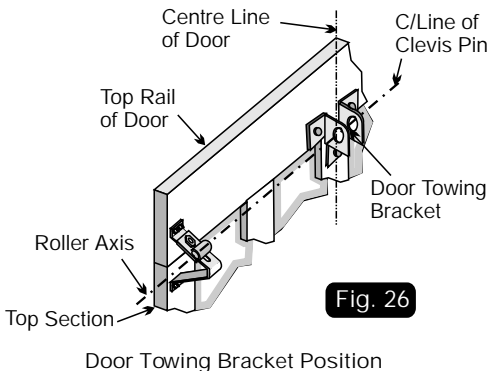

Fig. 26

4.8 Attaching the Towing Arms Onto Sectional Type Doors.

4.8.1 Use both the "L" Shaped Towing Arm and the Straight Towing Arm to couple the door to the traveller as shown in Fig 27. The "L" Arm is attached to the door whilst the Straight Arm is connected to the Traveller as shown.

4.8.2 Use the two 10 mm dia. Clevis Pins and 2,5 mm Split-Pins to couple the towing arm to the door bracket and traveller.

IMPORTANT NOTES :-

4.8.3 The towing arm should make an angle of between 75 and 80 degrees to the horizontal when the door is in the closed position.

4.8.4 The security of the locked door is a function of the angle which the "Towing Arm" makes with the horizontal.

15 degrees off the vertical is the optimum angle for Sectional type Doors.

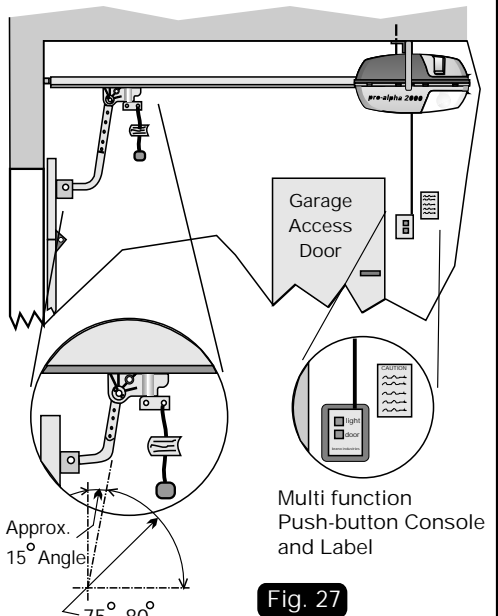

Fig. 27

Now turn to Section 6, page 18 for PC Board connections !

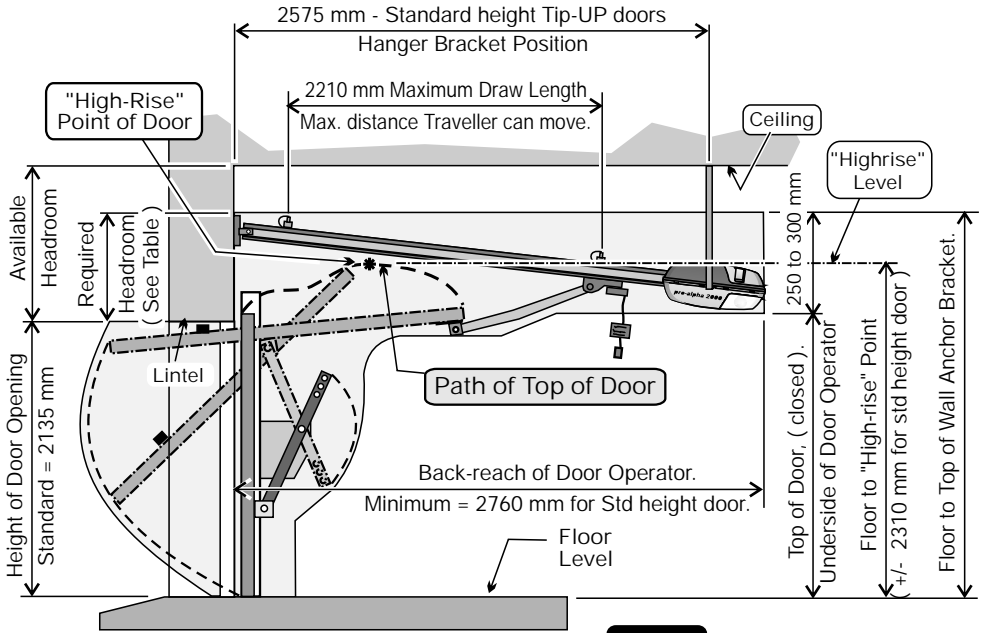

Fig. 28

5.1 Operator "Working Space"

Applicable to All Tip-Up Doors !!!

The same criteria as for Sectional doors apply to Tip-Up type doors.

See the diagram above and the relevant door installation manuals for specific information and dimensions.

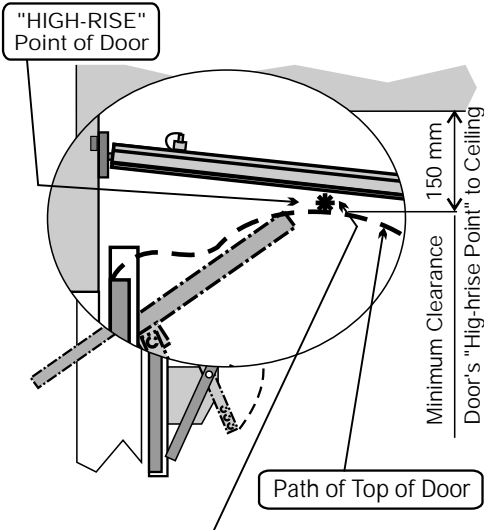

Tip-Up Doors
 Operator to Door
 Clearance at "high-rise"
 point 20- 50 mm

Fig. 29

Headroom Required for Tip-Up Doors
 (All dimensions in mm.)

| Steering Arm Setting | Optimum Headroom Required | * Minimum Headroom Required |
|----------------------|-------------------------------|-----------------------------|
| "Low" - 1 | Not suitable for automation ! | |
| "Normal" - 2 | 300 | 200 |
| "High" - 3 | 400 | 325 |

* Note:-If the Headroom Available is less than the minimum required, special equipment and / or doors may be required.

5.2 One-piece Trackless and Pivot Type Tip-Up Doors

- 5.2.1 The Door Bracket is attached to the door at the centre-line position as close to the top of the door as possible.
- 5.2.2 Use the three # 12 x 28 mm hex head Lag Screws provided to fix the Door Bracket to the door.

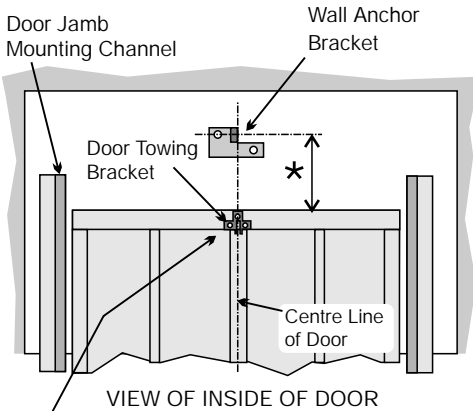

Fix the Door Towing Bracket as close to the top of the door as possible.

Fig. 30

5.3 Steering Arm Settings

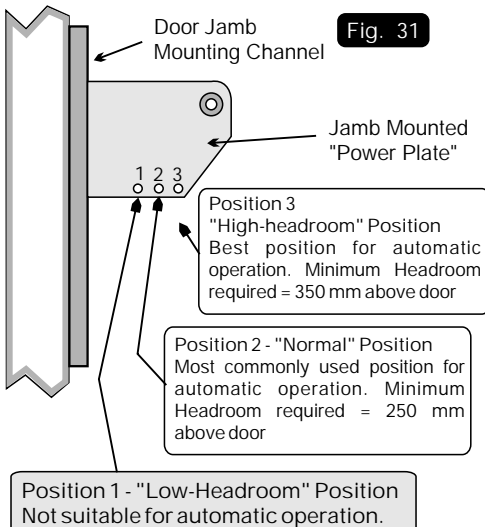

Fig. 31

5.4.1 Attaching the Towing Arm

Use the "Straight" Towing Arm, (Part 2TOWT), to couple the door to the traveller as shown in Fig. 32.

If the "L" shaped towing arm is to be used, (Part 2TOWLS), use the arrangement shown in Fig. 33.

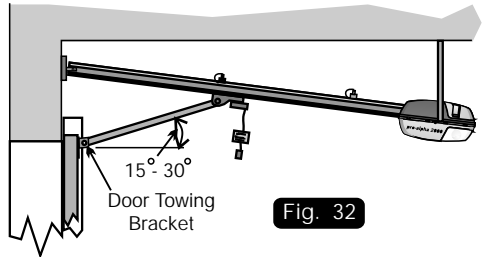

Fig. 32

Straight Towing Arm Arrangement

- 5.4.2 Use the two 10 mm dia. Clevis Pins and 2,5 mm dia. split-pins to couple the towing arm to the door bracket and traveller assembly.
- 5.4.3 **IMPORTANT :-** The angle between the Towing Arm and the horizontal plane should be as follows:-
 Tip-Up Doors - between 15 and 30 degrees to the horizontal when the door is in the closed position.

5.5 Alternative Towing Arm Arrangement for TIP-Up Door

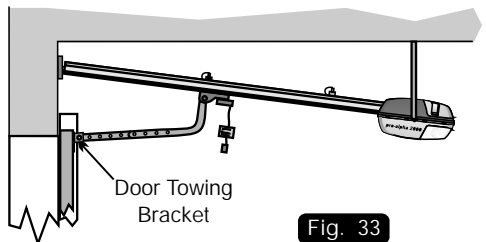

Fig. 33

"L" Shaped Towing Arm Arrangement

Now turn to Section 6, page 18 for PC Board connections.

5.6 Installation Of Door Operator On A Jamb-Spring System Tip-Up Door Using An Extended Towing Arm

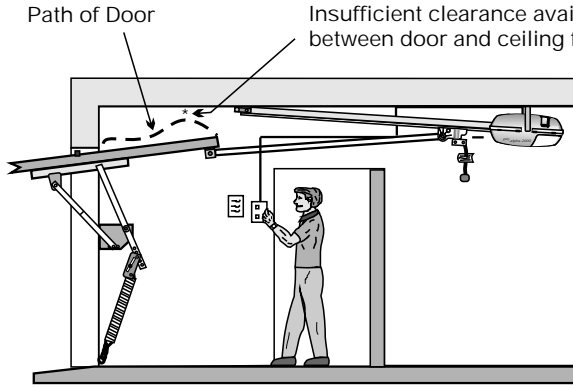

Fig No. 34

Installation In Garage With "Low Headroom"

"Trackless Tip-Up" Doors Only !!!

If there is insufficient clearance between the path of the door and the ceiling, it is permissible to move the motor back away from the door and fix the "Anchor Bracket", (or Header Bracket), to the ceiling and make use of an "Extended Towing Arm" to couple the door to the operator.

5.7 Installation Of Door Operator On A Sectional Door Having Insufficient Headroom For A Door Operator

"Highrise" Point.
Normal Path of Door with
standard type "Adjustable Top Roller
Bracket" Installed

Door Clearance Increased
by approximately 60 mm

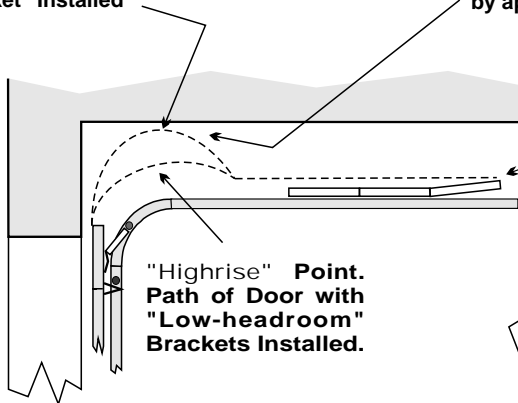

Fig No. 35

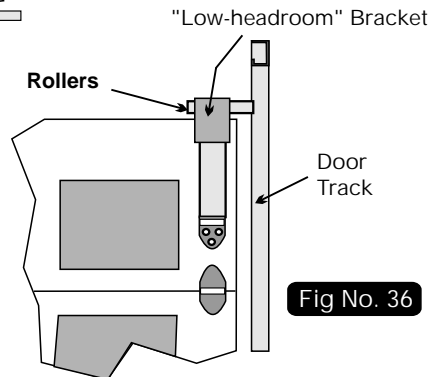

Fig No. 36

Automatic Door Installation

5.8 "Emergency Key-Release" Mechanism For Sectional and Tip-Up Doors

The "Emergency Key-Release" is a special mechanism which is fitted to a door when

..... the only access into the garage is through the garage doors themselves, i.e. there is no back or side door entrance into the garage.

This special release mechanism permits the manual operation of the door in the event of a power failure or other breakdown of the system.

The Installation procedure for both Sectional Doors (shown), and Tip-Up Doors is the same.

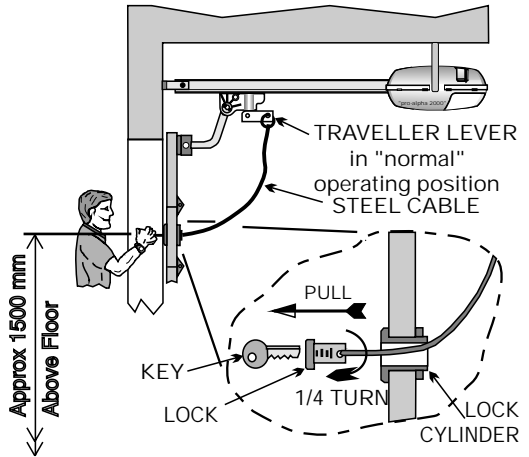

Fig No. 37

If you experience a problem Check the Installation !

If that doesn't help Read the Manual !

If the problem persists Book yourself into one of our Training Courses !

There is no substitute for doing it right the first time !

"pro-alpha 2000" PC BOARD - GENERAL LAY-OUT

"DOWN Over-load"
 Sensor Adjustment.
 (Sensitivity)

"UP Over-load"
 Sensor Adjustment.
 (Sensitivity)

Terminal Block for
 connection of Radio Receiver,
 Wall-Pushbutton and
 Safety Beams.

Fig. 38

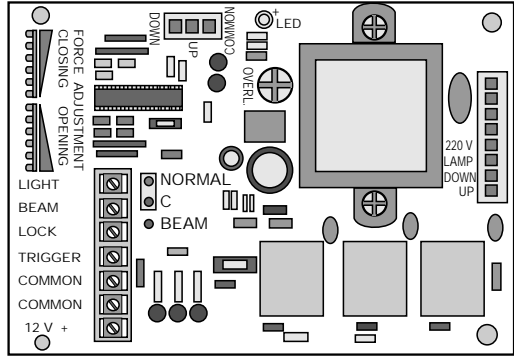

PC Board Lay-out

CONNECTING THE WALL PUSH-BUTTON

Connect the Wall-Pushbutton as shown.

Take Note:-

- 1) If no "Safety Beams" are to be fitted then the PC Board "jumper switch" must be set to the "Normal" position.
- 2) The wire colours shown, (White, Brown, etc.), are typical only. The colours of the wires as supplied may vary from those shown.

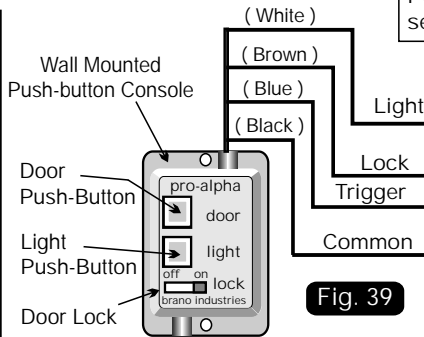
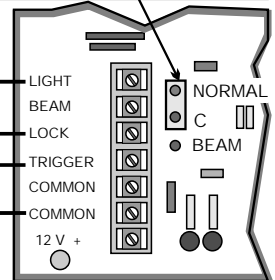

Fig. 39

Note:-
 PC Board jumper switch is set to "NORMAL" position.



Operator PC Board

CONNECTING THE RADIO RECEIVER
 (Simple Dipswitch Type)

Connect the Radio Receiver as shown.

Take Note:-

- 1) If no "Safety Beams" are to be fitted then the PC Board "jumper switch" must be set to the "Normal" position.
- 2) The wire colours as supplied may vary from those shown.

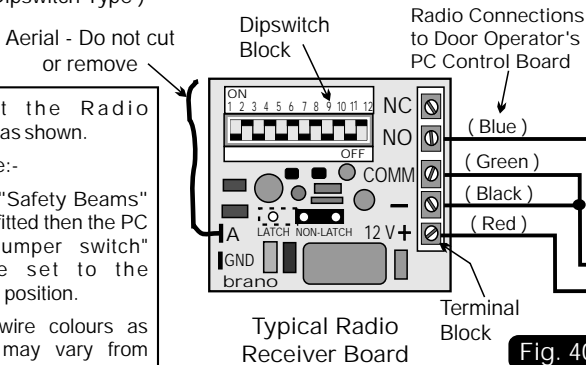
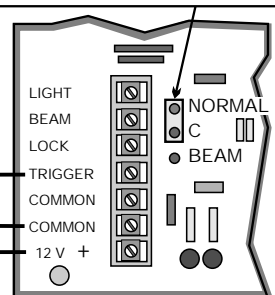

Fig. 40

Note:-
 PC Board jumper switch is set to "NORMAL" position.



Operator PC Board

WARNING! WARNING! WARNING!

Do not work on the operator whilst the power supply is connected and switched "On" !!!

6.1 Wall Mounted Pushbutton Console:-

Connect up the Pushbutton and run the pushbutton wires to the opener. See page 18 for connection details.

6.2 Radio Controls:-

Code the radio remote controls in accordance with the manufacturer's instructions.

The 12 V Power Supply for the receiver is provided on the PC Board.

6.2.1 Connect up the Radio Receiver as follows:-

- "Red" to 12 VDC input.
- "Blue" to Trigger.
- "Black" to Negative.
- "Green" to Common.

Refer to Radio Manufacturer's manual for detailed instructions.

Holes are provided in the Top Service Cover of the operator through which the Radio Control and Push-button wires may pass.

6.3 Optional Mounting Position for Radio Receiver

An ideal place to mount the Radio Receiver is shown in Fig. 41

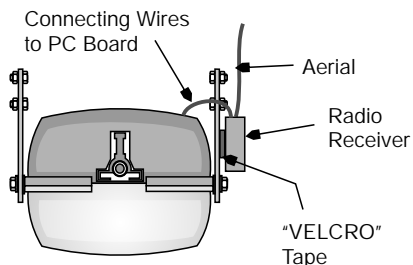
**Fig. 41****6.4 Main Power Supply:-**

A 3 pin 10A Kettle Connector, ("International" type) is provided at the rear of the opener for coupling up to the main power supply. A suitable "kettle" type connector plug is provided as part of the "pro-alpha 2000" kit.

6.5 Lamp:-

Insert the lamp into the lamp holder provided. Maximum 100 W "Bayonet" type base "Rough Service Duty" lamp is recommended.

NOTE:-

The power supply cord, 15 A plug top and lamp are not supplied as part of the "pro-alpha 2000" kit.

6.6 Safety Beams and Pressure-Sensitive Sensing Devices:- (See Fig 42)

Provision is made directly on the PC Board of the "pro-alpha 2000" door operator to install various types of "safety beams" and "pressure sensors".

Refer to the relevant manufacturers instructions for connecting information.

IMPORTANT NOTE:-

The operator's PC Control Board is not able to provide the power source for beams and other safety devices. These items of equipment must be provided with their own independent power sources.

6.7 Connecting "Safety Beams"

Fig. 42

Note:-
 PC Board jumper switch is set to "BEAM" position.

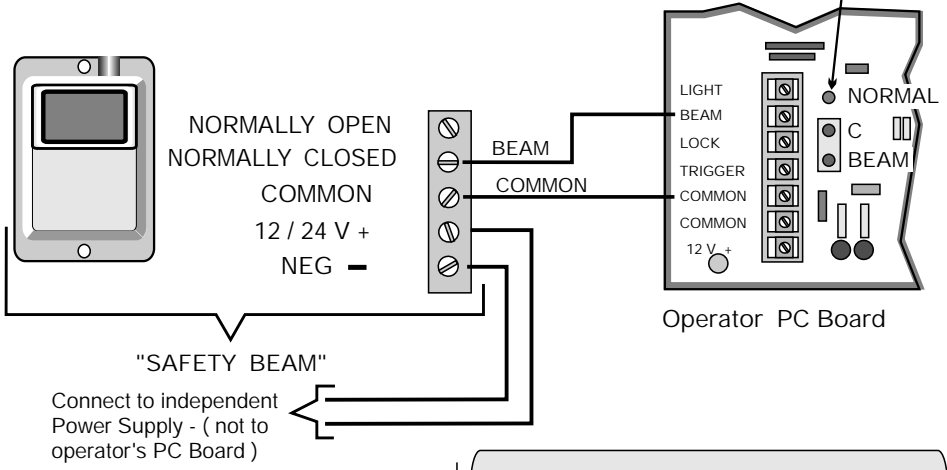

Connect the "Safety Beam" as shown.
 Take Note:-
 When "Safety Beams" are fitted then the PC Board "jumper switch" must be set to the "BEAM" position.
 The "Normally Closed" contact of the Safety Beam is the one used for connecting the beams to the Operator PC Board.

These connection diagrams are intended to serve as a guide only.
 Always refer to the instructions supplied by the equipment manufacturer for specific information.

Now turn to Section 7, page 21, for setting-up instructions of the Limit Switches and Overload Sensor Adjustors !

- If you experience a problem Check the Installation !
- If that doesn't help Read the Manual !
- If the problem persists Book yourself onto one of our Training Courses!

There is no substitute for doing it right the first time !!!

7 LIMIT SWITCH SETTINGS
(All types of doors)

7.1 "UP" Limit Switch

- 7.1.1 First ! Open and close the door manually to ensure that it does not foul any part of the operator.
- 7.1.2 Second ! Manually open the door to the full open position
- 7.1.3 Next ! Move the "up" Limit Switch towards the Traveller Trip-Arm until contact is made.
- 7.1.4 Now ! Secure the "up" Limit Switch Bracket by means of it's securing screw and connect the brown wire to the "up" Limit Switch Terminal and crimp in place.

7.2 "DOWN" Limit Switch

- 7.2.1 Manually close the door.
- 7.2.2 Move the "down" Limit Switch towards the Traveller Trip-Arm until contact is made.
- 7.2.3 Secure the Limit Switch Bracket by means of it's securing screw and connect the purple wire to the "down" Limit Switch Terminal and crimp in place.

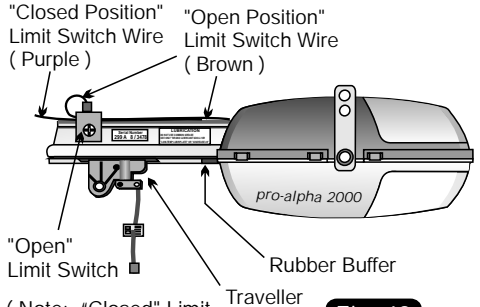

(Note:- "Closed" Limit Switch not shown) **Fig. 43**

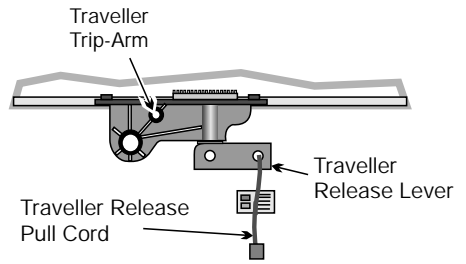

7.3 Over-Load Sensor Adjustments
"Sensitivity" Settings (All Types of Doors)

The "Sensitivity" settings are pre-set at the factory. Under normal circumstances it should not be necessary for these settings to be changed except to "fine-tune" them.

Resist the temptation to set the operator to be too sensitive. A "positive" force of between 5 - 10 kg. is desirable for domestic garage doors.

7.3.1 Opening Force Adjustment

Stand clear of the path of the door !

7.3.1.1 Operate the door in the opening mode. Whilst the door is in motion, obstruct the door by grabbing hold of the bottom rail or pushing down on the handle. The door should stop its motion once it encounters a resisting force of 5 - 10 kg.

7.3.1.2 If adjustment is required, move the "Up" sensor adjustment lever in the appropriate direction as shown on the legend on the PC Board.

The right hand side lever controls the "Up" sensitivity.

IMPORTANT NOTE

Make sure that the operator stops on contact with the Travel Limit Switches and not on the "safety overload", (i.e. sensitivity), switches.

If, whilst in the closing mode, the door stops and then immediately reopens, readjust the "down" Travel Limit Switch. The operator is driving the door too far downwards !!!

Do not try to get the door operator to stop in the "down" mode by increasing the force setting, (i.e. reducing the sensitivity of the operator).

The operator must stop on contact with the Travel Limit Switch only !!!

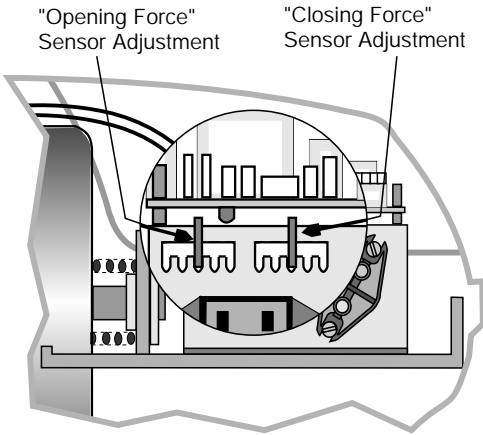

Fig. 44

7.4 Closing Force Adjustment

Stand clear of the path of the door !

7.4.1 Cycle the door in the closing mode.

7.4.2 As the door closes, obstruct the door by grabbing the bottom rail of the door, or the door handle if one is fitted. The door should react to this obstruction by first stopping and then reversing its motion to the opening mode.

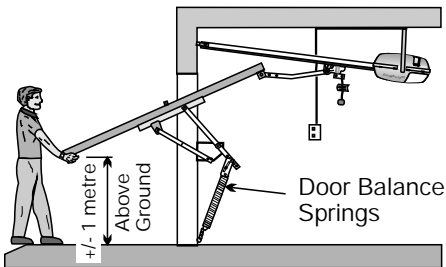

Testing the "Sensitivity" Settings of the Door Operator

Fig. 45

The door should exert a downward force of no more than 5 - 10 kg. before the safety reverse mechanism of the "pro-alpha 2000" door operator is activated. For doors in good working

order, a downward force of 5 - 10 kg. is considered optimum.

7.4.3 The left hand side lever controls the "Down" sensitivity.

7.4.4 Note:-

The application of paint, timberseal or varnish to a wooden garage door can add a considerable amount of extra weight to the door. The safety reverse mechanism of the operator should always be checked after any painting operations have been carried out.

7.4.5 Don't be tempted to set the closing force adjustment to be too sensitive. Take into account the extra effort that is required to move the door in conditions of strong wind, or in the case of a wooden door for example, the extra weight the door can gain when it is wet!!!

The operator should be set to pull and push with a force of between 5 - 10 Kg. !.....

... Regardless of the size of the door !

7.5 The "Safety Overload" Feature will be automatically activated when

☞ An obstruction is encountered by the door whilst it is opening,

..... the door will stop!!!

☞ Take Note:- ...

The door will not reverse its direction whilst it is in the "opening mode".

..... It will stop!!!

☞ An obstruction is encountered by the door whilst it is closing,

..... the door will first stop and then automatically reverse it's direction and move to the "full-open" position.



8.1 "POWER ON" TEST

Ensure that the Traveller is disengaged, i.e. the door is not coupled to the operator.

- 8.1.1 Switch the power supply "ON".
- 8.1.2 Check that the Red "Power-On" indicator light situated under the PC Board is illuminated.
- 8.1.3 Using either the Transmitter or the Wall-mounted Push-button, cycle the operator to check that it starts and stops as it should, and that the Lamp and Radio Controls are operative.

8.2 OPERATING TEST

Ensure that the Door Lock Catches are disengaged, i.e. the catches must be in the "Open" or "unlocked" position.

- 8.2.1 First!... Couple the door to the operator by engaging the traveller with the worm screw. The traveller is engaged when the Traveller Lever is in the "horizontal" position. Make sure that there are no obstructions in the path of the door.
- 8.2.2 Next!... Cycle the operator to it's "full open" and "closed" positions, by pressing the push-button marked "DOOR".

Check that the Traveller does not overrun the Limit Switches. The Traveller should stop at the "UP" and "DOWN" Limit Switches respectively.
- 8.2.3 Fine adjustments of the Limit Switch settings may now be made.

8.3 TESTING THE COURTESY LIGHT and DOOR LOCK-OUT FUNCTION

- 8.3.1 Check that the Courtesy Light functions correctly. With the door in the closed position, press the button marked "LIGHT" on the Wall Push-Button Console. The operator's courtesy light should switch "on" without the door being activated. The courtesy light should switch itself "off" automatically after 3 to 4 minutes.
- 8.3.2 Again switch on the Courtesy Light. After a few seconds, press the button a second time. The courtesy light should now switch "off".

8.4 DOOR LOCK-OUT FUNCTION

- 8.4.1 The door lock-out function is activated by moving the "slide" switch to the "lock" position.

8.5 OPERATOR FUNCTIONS

Pressing the "DOOR" Button Once.....

If the door is "closed",

the motor and courtesy light will switch "ON", and the door will "open"!

If the door is "open",

the motor and courtesy light will switch "ON", and the door will "close"!

If the door is "opening", (still in motion),

..... the door will stop!

If the door is "closing", (still in motion),

..... the door will stop!

8.6 OPERATOR COMMISSIONING and PERFORMANCE CHECKS

CHECK THE FOLLOWING:-

- 8.6.1 The door should open to its normal height as specified by the door manufacturer.
- 8.6.2 Door closes completely without imposing undue strain on the operator.
- 8.6.3 Overload sensitivity is properly set for both opening and closing modes, (i.e. safety reverse function).
- 8.6.4 If the door strikes an obstruction whilst in the "closing mode", it should first stop and then automatically reverse its direction to the "full-open" position.
- 8.6.5 In the "opening mode" the door must come to a complete stop should it strike an obstruction.
- 8.6.6 The Emergency Manual Release Mechanism functions correctly with the door in both the "open" and "closed" positions.
- 8.6.7 The Courtesy Light timer is operative.
- 8.6.8 The Radio Controls function properly.
- 8.6.9 The Wall Push-Button Control functions correctly.

8.7 CYCLE TIMES :-

Times are given for Standard Height Doors, i.e. 2135 mm high, (7 ft.)

Sectional Doors approx. 18 seconds.

Tip-Up Doors (Pantograph type).

..... approx. 9 seconds.

Steel Roll-Up Doors approx. 16 seconds.

8.8 "INFORMATION" LABELS

The Law requires that certain "information" labels be displayed in prominent positions close to the garage door and door operator where they may be seen and read by all users of the equipment.

It is the responsibility of the installer to ensure that this is done !!!

Failure to do so may result in the installer / dealer being held liable in the event of persons being injured or property being damaged by the door system !!!

8.8.1 Danger Warning Label

This label is to be fixed to inside "face" of the garage door approx. 1500 mm above the floor.



8.8.2 Caution Label

This label is to be placed next to the Wall Push-button.

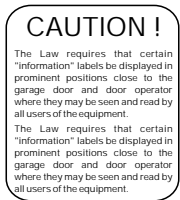

8.8.3 "Emergency Key-release" Label

This label is attached to the "red" cord which is fixed to the Traveller Release Lever.

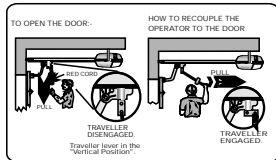

8.8.4 Certificate of Compliance and Door Inspection

This label is to be fixed to inside "face" of the garage door approx. 1500 mm above the floor.

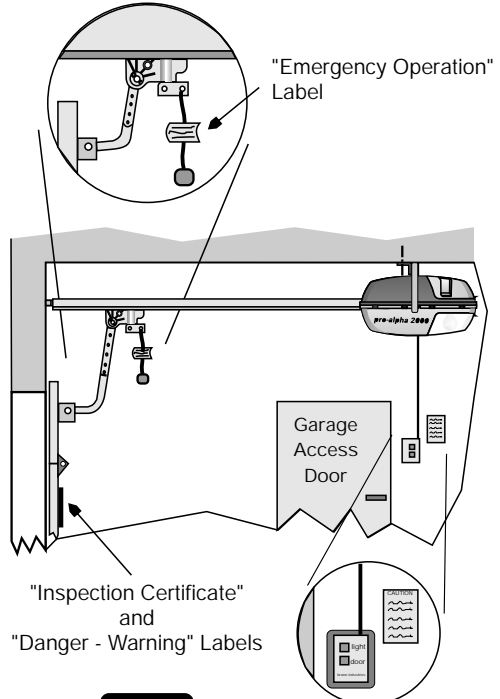

Fig. 46

Push-button Console and "Caution" Label

8.9 "Handing Over" The Finished Job.

Perhaps the most important part of the installation is the "hand over" to the client when it is complete.

The system should be demonstrated to the end-user!

Be sure to demonstrate the correct use of the equipment, especially how to operate the door in the event of a power-failure.

Demonstrate to the client that the "Safety Overload Sensing System" is functioning correctly.

Equally important is to demonstrate how to test the system for correct performance and how to inspect the door for signs of wear and damage!

9.1 SERVICE and MAINTENANCE

The Brano "pro-alpha" Garage Door Operator is designed for "minimum maintenance", and if correctly installed, the only servicing necessary is periodic lubrication of the wormscrew

.....Approximately every 3 months.

9.2 LUBRICATION

Very Important

A special lubricant is required for the Worm-shaft.

Use only :-

Brano Lubricant - GDO L 1

or "MOBIL AVGREASE 28"

or "MOBIL Low-Temp Lubriplate SHC-100"

or "AERO SHELL Grease No 6"

Take Note:-

Do not use any other type of common grease or lubricant !!

Use of the incorrect lubricant will cause serious and permanent damage to the operator.

Do not apply too much grease. Use sparingly!

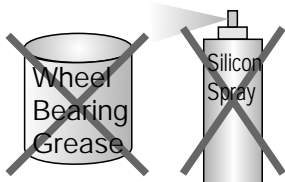

Do not apply to Worm-shaft

Fig. 47

- 👍 The motor is fitted with sealed bearings which are lubricated for life.
- 👍 There are no other components in the Brano "pro-alpha 2000" garage door operator which require lubrication.

9.3 WEARING PARTS

Two components of the "pro-alpha 2000" garage door operator are intentionally designed to be "sacrificial" wearing parts, namely the Traveller and the Worm-shaft Coupling.

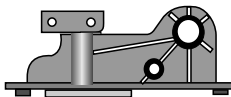

Traveller Assembly



Worm-shaft Coupling

Fig. 48

If either of these two components fails, it is usually an indication that something is not as it should be with the door system. Most likely it is an indication that the "balance" of the door is not correct. It may be that a spring is stretched or broken and needs to be replaced or some other component is unserviceable.

The Traveller and Coupling may also become damaged if the door has suffered an impact with a car or has been "forced" open. Whatever the cause, the entire system needs to be carefully inspected.

The reasons for making these 2 components "sacrificial" wearing parts are:-

- 1 These are the easiest parts to replace!
- 2 These are the cheapest parts to replace!
- 3 Both of these items can be replaced without the need for special tools. The repair can be effected "on site".
- 4 By being designed to "fail first" they protect more expensive and more "difficult-to-replace" components of the operator.

IMPORTANT NOTE !

Although the Traveller and Worm-shaft Coupling are designed to "fail first", they are not intended to act as a "back-up safety system" to prevent injury to persons who are entrapped or struck by the garage door.

The responsibility remains with the user of the door to ensure that it is maintained in a serviceable condition at all times.







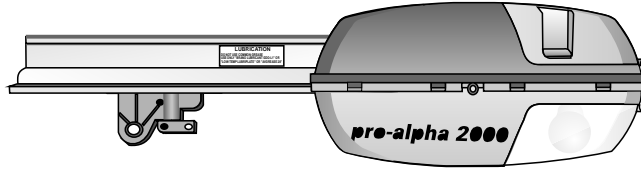

Inspect the door and operator regularly for signs of wear and tear and damage!

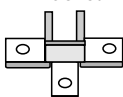
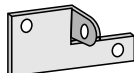
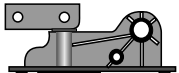

SECTION 10
"pro-alpha 2000"
 GARAGE DOOR OPERATOR
 MECHANICAL SPARE PARTS

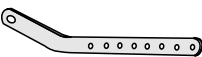
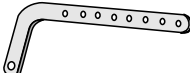

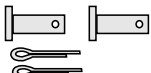
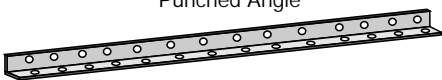
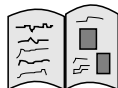
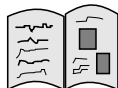
| | |
|---|--|
| 1 | Door Type:- Sectional Stock Code:- 1 PA 2001 |
| 2 | Door Type:- Tip-Up Stock Code:- 1 PA 2002 |
| 3 | Door Type:- Steel Roll-Up Stock Code:- 1 PA 2003 |
| 4 | Door Type:- Caravan Stock Code:- 1 PA 2004 |
| 5 | Door Type:- Steel Roll-Up Stock Code:- 1 PA 2005 "Pro-Rola" System |

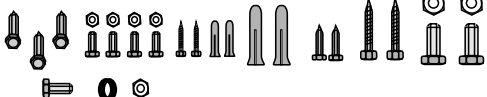
| | | | |
|--|---|--|--|
| <p>Travel Limit Switches</p>  <p>2 ESL</p> | <p>Door Towing Bracket</p>  <p>2 BRAD</p> | <p>Door Header Anchor Bracket</p>  <p>2 BRAHE</p> | <p>Traveller Assembly</p>  <p>2 TRAV - 01</p> |
| <p>Power Cord "Kettle-Cord Connector"</p>  <p>2 EPK</p> | <p>Wall Push-button complete</p>  <p>2 ESW</p> | <p>4 Core Comm-Cable (Push-button)</p>  <p>EW 4 TEL</p> | <p>Emergency Release Pull-Cord</p>  <p>2 CORD</p> |
| <p>Towing Arm "Tip-up" Doors</p>  <p>2 TOWT</p> | <p>"L" Towing Arm "Sectional" Doors</p>  <p>2 TOWLS</p> | <p>"Straight" Towing Arm "Sectional" Doors</p>  <p>2 TOWSS</p> | <p>"Clevis" Pin</p>  <p>4 FPC 1028</p> |
| <p>20 x 20 x 1500 mm Punched Angle</p>  <p>1 AP 20</p> | | <p>"Owner's Instruction Manual"</p>  <p>MAN - 01</p> | <p>"Installer's Instruction Manual"</p>  <p>MAN - 02</p> |
| <p>"Caution" Label</p>  <p>LAB 02</p> | <p>"Emergency Operation" Label</p>  <p>LAB 04</p> | <p>Fastener Bag</p>  <p>4 FK PA</p> | |

"brano door operator installation manual"

SECTION 10
"pro-alpha 2000"
 Electrical and Miscellaneous
 Spare Parts

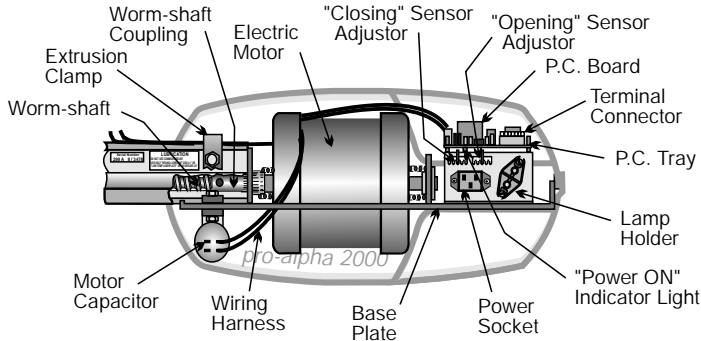

P C Board (Control Card) PA 2000 Series

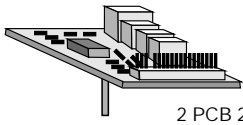

Model DO - 10
 Note:- Not interchangeable with "pro-alpha" Series 1 PC Boards

2 PCB 2

3 Pin Power Socket

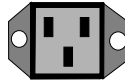

2 EWH

Motor Hanger Bracket



2 BRAH

Motor Capacitor

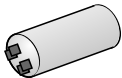

2 ECAP

Lamp Holder



ELH

Electric Motor

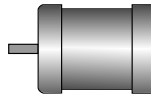

EMOT

Worm-Shaft Coupling



COUPN

Thrust Bearing



BEAT

Overload Wire



SPRW

Guide Bush



BUSHG

Motor Compression Spring



SPRC

Grease



1 GR 100

Guide Pin

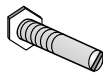

FGP 532

Guide Pin with Bobbin

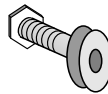

2 GUIDE PIN LNG

Thrust Washer



THRST

Worm-Shaft and Aluminium Housing (Extrusion)

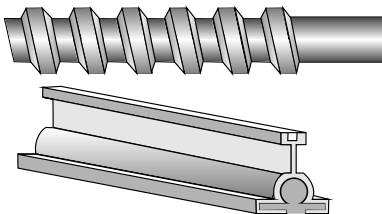

Important Note
 The Worm-shaft and Aluminium Extrusion are sold as a "matched pair" only!

2 REP - 03 Sectional Door Shaft and Extrusion

2 REP - 04 Tip-Up Door Shaft and Extrusion

2 REP - 05 Roll-Up Door Shaft and Extrusion

2 REP - 06 Caravan Sectional Door Shaft and Extrusion

"brano door operator installation manual"



SECTION 11
"pro-alpha 2000"
TROUBLE SHOOTING GUIDE

SYMPTOM 1 :-

Operator Does Not Work At All.

- ✿ The operator remains silent and does not respond to either the Wall Push-button or the Transmitter.
- ✿ The Courtesy Light does not switch "ON".
- ✿ "Power-On" indicator light remains "OFF".

SOLUTIONS 1 :-

- 1.1 Electric power is not being supplied to the operator.
- 1.2 Check that the Power Plug at the side of the operator is correctly inserted into the socket.
- 1.3 Check that the power supply outlet, distribution board, fuses, mains earth leakage, etc. are correctly wired and are operating correctly.
- 1.4 Check for breaks in the Power Supply Cable.
- 1.5 Check the PC Control Board for damage, e.g. from a lightning strike, power-surge, etc.

SYMPTOM 2 :-

Operator makes a "click" sound and the "Courtesy Light" switches "ON", but the motor remains "silent" and will not "run".

SOLUTIONS 2 :-

- 2.1 Check the manual operation of the door.
- 2.2 Check that the Travel Limit Switches are set correctly and are not damaged.

SYMPTOM 3 :-

The operator "clicks", the "Courtesy Light" switches "ON" and the motor "hums", but Worm-Screw does not turn.

SOLUTIONS 3 :-

- 3.1 Check the manual operation of the door. The door may be jammed or obstructed. The Door Locks may be engaged. The manual door locks must be "disengaged" for automatic operation.

- 3.2 The Worm-Shaft may be jammed or seized due to the ingress of dirt or some other foreign matter. Clean out the Aluminium Extrusion with paraffin and re-grease the worm-screw.
- 3.3 The Worm-Screw can become seized if the incorrect type of grease is used. Refer to the section "Lubrication" in this manual.
- 3.4 The "Travel Limit Switches" and the "Overload Sensor" may be incorrectly set. Reset the Limit Switches and check the sensitivity setting of the operator.
- 3.5 Check the Operator for signs of damage, (as may be caused during a forced entry).
- 3.6 The Motor Coupling may be damaged.

SYMPTOM 4 :-

- ✿ Operator switches "ON" and "runs", but door does not move.
- ✿ Worm-Screw "turns" but door remains stationary.

SOLUTIONS 4 :-

- 4.1 Check that the Traveller Lever is in the engaged position for the particular type of door.
- 4.2 Check for damage or excessive wear to the Traveller Nut.
- 4.3 The Motor Coupling may be damaged.

SYMPTOM 5 :-

- ✿ Operator works in one direction only.
- ✿ Door "opens", but will not "close".
- ✿ Door "closes", but will not "open".

SOLUTIONS 5 :-

- 5.1 Check the Travel Limit Switches for damage.
- 5.2 Inspect the limit switch wires for damage.

TROUBLE SHOOTING GUIDE
(Section 10 continued)

SYMPTOM 6 :-

Operator "runs" a short distance in the "closing" direction", then stops for no apparent reason and then reverses it's direction, "runs" a short distance again then stops completely.

SOLUTIONS 6 :-

- 6.1 Check the "Down" Overload Sensor. The "Down" sensitivity may be set to be too sensitive.
- 6.2 Increase the "closing force" by moving Sensor Adjustment Lever "one notch at a time" as indicated on the PC Board.

SYMPTOM 7 :-

Operator "runs a short distance in the "Opening" direction then stops completely for no apparent reason.

SOLUTIONS 7 :-

- 7.1 Check the "UP" Overload Sensor. The "UP" sensitivity may be set to be too sensitive. Increase the "opening force" by moving the Sensor Adjustment Lever one notch at a time as indicated on the PC Board.

SYMPTOM 8 :-

Operator works from the Wall Push-button, but not from the remote Transmitter.

SOLUTIONS 8 :-

- 8.1 Check the Battery in the Transmitter. Replace the battery at least every 6 months. Keep a spare Transmitter in a safe place for emergency use!
- 8.2 Check that the codes of both the Transmitter and the Receiver are identical to each other.
- 8.3 Check that the wires from the Receiver to the operator are properly connected.

8.4 Check that the Transmitter is working correctly.

8.5 Check that the Receiver is functioning correctly.

SYMPTOM 9 :-

Operator works from the "Transmitter" but not from the "Wall Push-button"

SOLUTIONS 9 :-

- 9.1 Inspect the Wall Push-Button Console for damage.
- 9.2 Inspect the Push-Button Wires for damage and proper connections to the operator.

SYMPTOM 10 :-

Operator works but the Courtesy Light does not switch "ON".

SOLUTIONS 10 :-

- 10.1 Check the Lamp and replace if necessary.
- 10.2 Check the PC Control Board and replace if necessary.

SYMPTOM 11 :-

Door "shudders" and "jerks" as it opens and closes. Action is not smooth and continuous.

SOLUTIONS 11 :-

- 11.1 The Door may be incorrectly installed.
- 11.2 Check the manual operation of door. The door may be obstructed, or may be fouling the garage structure.
- 11.3 Inspect the door for damaged and worn or missing parts.
Repair or replace as necessary !
- 11.4 The Door Operator may be incorrectly installed.
- 11.5 The operator may not be compatible with the type of door onto which it is fitted.
- 11.6 The door itself may not be suitable for automatic operation.
- 11.7 Consult your "pro-alpha" dealer for advice.

SYMPTOM 12 :-

Door starts to Open then "stops" for no apparent reason before it can complete it's cycle.

SOLUTIONS 12 :-

- 12.1 Check the manual operation of the door.
- 12.2 Check the limit switch settings. The door may be fouling the Travel Limit Switches.
- 12.3 Overload Sensor is set too sensitive for the opening mode. Increase the opening force, i.e. "UP" force.
- 12.4 Be careful not to activate the transmitter inadvertently. Do not keep the transmitter in your pocket or handbag, or allow children to play with it.

SYMPTOM 13 :-

Door starts to Close then "stops" for no apparent reason before it can complete it's cycle.

SOLUTIONS 13 :-

- 13.1 Check that the Travel Limit Switches are functioning correctly
- 13.2 Check that the Travel Limit Switches are not being fouled by the door as it moves.

SYMPTOM 14 :-

Note this condition carefully!

Door starts to "close" but "stops", and then "reverses it's direction" for no apparent reason before completing it's cycle and returns to the "full - open" position.

SOLUTIONS 14 :-

- 14.1 Check the manual operation of the door. The door may be obstructed or damaged and is not able to complete it's cycle.
- 14.2 The Overload Sensor is set too sensitive for the "closing" mode. Increase the "closing force", i.e. the "down-force", by "decreasing" the sensitivity setting.

SYMPTOM 15 :-

Door does not "Open" or "Close" fully.

SOLUTIONS 15 :-

- 15.1 The door may be fouling the Travel Limit Switches as it moves. Reposition the limit switches or raise the operator to clear the door.
- 15.2 Note:-
Certain types of doors have a limit as to how high they may be opened when converted to "automatic" operation.
See 13 and 14 above.

SYMPTOM 16 :-

Door activates itself for no apparent reason.

SOLUTIONS 16 :-

- 16.1 A neighbour may be using radio control equipment which is set to the same signal code. Change the Dip-switch Codes of both the Transmitter and Receiver.
- 16.2 The Radio Receiver may be located in a place where the radio reception is weak or else the signal is being screened or interfered with, e.g. close to steel doors, close to fluorescent lamps, close to powerful radio, microwave or television broadcasting equipment, etc.
- 16.3 The Radio Receiver may be faulty.
- 16.4 The Wall Push-button may be faulty.
- 16.5 The PC Control Board may be faulty.

SYMPTOM 17 :-

The operating range of the Remote Radio Transmitter is very short.

SOLUTIONS 17 :-

- 17.1 Replace the Battery in the Transmitter.
- 17.2 The Radio Transmitter may be faulty.
- 17.3 The Radio Receiver may be poorly located. Move the receiver to another location.
- 17.4 The Radio Receiver may be faulty.
- 17.5 NOTE:-
The performance of low-power radio remote control equipment in areas close to broadcasting centres, microwave communication towers, airports, etc., is often very restricted. In such cases it may be necessary to install special radio controls which operate in the 27 MHz frequency band.

TROUBLE SHOOTING GUIDE
(Section 10 continued)

SYMPTOM 18 :-

The Courtesy Light does not switch "On".

The Courtesy Light does not switch "Off" automatically, (i.e. the light remains "On"continuously).

SOLUTIONS 18 :-

- 18.1 Check that the wall mounted "Push-Button" is correctly wired and that all the contacts are "Normally Open".
- 18.2 Check that the push-button switch contacts are not wet. Moisture inside the switch can cause a short circuit.
- 18.3 The Push-Button Wires may be crossed.

SYMPTOM 19 :-

The operator works but is very noisy.

SOLUTIONS 19 :-

- 19.1 The Worm-screw may require lubrication. Lubricate the shaft with the special grease as specified. Use only the type and grade of grease stipulated.
- 19.2 The Worm-screw and Aluminium Housing may have been damaged and will need to be repaired or replaced.
- 19.3 The Motor Coupling may be worn or broken.
- 19.4 Test the manual operation of the door. The door may be damaged or require realignment or adjustment.
An unbalanced door can adversely affect the performance of the door operator.
- 19.5 Inspect the door and operator for loose fittings and fasteners and rectify.

SYMPTOM 20 :-

The door "closes" completely and then immediately re-opens by itself to the "full-open" position.

SOLUTIONS 20 :-

- 20.1 Check that the Travel Limit Switch Wires are properly inserted into the Limit Switch Terminals.
- 20.2 The Travel Limit Switch Brackets may be loose and have moved. Set them in the correct position and secure in place.
- 20.3 The PC Control Board may be faulty.

SYMPTOM 21 :-

- ☼ The Operator works but fails to respond to any obstruction which is in it's way.
- ☼ Operator will not "Reverse" if obstructed whilst in the closing mode, i.e. the automatic "Safety Reverse" is not functioning.
- ☼ Operator will not "Stop" if obstructed whilst in the opening mode, i.e. the automatic "Safety Stop" is not functioning.

SOLUTIONS 21 :-

- 21.1 Check the manual operation of the door.
- 21.2 The door must be properly balanced and in good working order.
- 21.3 Inspect the door for faulty or damaged parts.
- 21.4 Check the Over-load Sensor settings of the door operator.



SECTION 12
TERMS and CONDITIONS of "STANDARD"
and "EXTENDED" WARRANTIES

1 DEFINITIONS:-

In these terms and conditions:-

- 1.1 Brano shall mean Brano Industries (Pty) Ltd. or its subsidiaries or successors in title or assign.
- 1.2 The "owner", "purchaser", or "end user" shall mean the individual in whose name the ownership of the equipment is registered in terms of this agreement.
- 1.3 "Distributor" shall mean the wholesaler or distribution agent appointed by Brano.
- 1.4 "Dealer" or "Installer" who acts as a re-seller of the equipment and who may also do the installation of the equipment.

2 SCOPE OF SUPPLY:-

This Warranty applies only to the garage door operator itself. Radio remote controls, accessories such as door conversion and adaptor kits, the garage doors themselves, site work, labour or travelling expenses are not considered as integral to the scope of supply.

3 GENERAL CONDITIONS of WARRANTY

- 3.1 This is an agreement between Brano and the owner of the door operator and covers the equipment only. The installer of the equipment must provide a separate warranty covering the installation work / workmanship.
- 3.2 This Warranty covers the "pro-alpha 2000" garage door operator against faulty or defective materials, components and / or manufacturing workmanship for a period of 12 months under the "Standard" Warranty, or 3 years under the "Extended Life" Warranty, from the date of purchase.
- 3.3 Brano undertakes to repair or replace, at its sole discretion, free of charge, any component of the "pro-alpha 2000" garage door operator as listed herein, subject to the conditions stated herein. Please note the exclusions to this warranty.
- 3.4 Incidental and Consequential Losses. Under no circumstances will Brano accept liability for "incidental" and / or "consequential" losses, (damages), resulting from the use of the equipment

4 "STANDARD 12 MONTH" WARRANTY

- 4.1 The "Standard 12 Month" Warranty applies to all "pro-alpha 2000" garage door operators provided they are installed in accordance with the installation instructions issued with the machine. The specific instructions issued by Brano relating to the particular door being automated must be observed in full. The 12 month period shall be calculated with effect from the date of installation as stated on the Warranty Registration card.
- 4.2 Operators which do not qualify for the "3 Year Extended Life" Warranty will be covered by the "Standard 12 Month" Warranty subject to the terms and conditions stated herein.
- 4.3 As with the "3 Year Extended Life" Warranty", Items such as Radio Remote Controls etc., which are manufactured by third parties shall be subject to the warranties / guarantees given by said third parties.

5 "3 YEAR EXTENDED LIFE" WARRANTY

- 5.1 Subject to the conditions stated herein, the "pro-alpha 2000" door operator is warranted to be free of defect for a period of 3 (three) years from the date of purchase.
- 5.2 The "3 Year Extended Life" Warranty applies only to door operators which are fitted to doors which do not require any special adaptor or converter kits or any other type of modification in order to make them suitable for conversion to automatic operation.
Doors such as Sectional type and Spring-Pantograph Tip-Up type doors qualify for coverage under this warranty. In every instance the installation of the door operator shall be strictly in accordance with the prescribed installation instructions.
Door Operators fitted to any other types of doors e.g. Vertically-Tracked Tip-Up doors or Horizontally Sliding doors, regardless of age, will not qualify for the "3 Year Extended Life" Warranty!
- 5.3 In respect of domestic Steel Roll-Up type doors, Brano does offer the "3 Year Extended Life Warranty" subject to the following additional conditions :-
 - 5.3.1 the door is less than 12 months old and is in good working order at the time of installation of the operator.
 - 5.3.2 the warranty shall apply only to doors which are fitted with the "Pro-Rola" adaptor system. The extended warranty shall not apply to installations which utilise the "Side-Mount" or any type of adaptor system.
 - 5.3.3 Proof of date of purchase of the door is required.

6 EXCLUSIONS - Items Excluded From This Warranty

Specifically excluded from the scope of this warranty is equipment such as:-

- 6.1 radio remote controls,
- 6.2 safety beams and door safety edges,
- 6.3 the garage doors "per se" and door hardware,
- 6.4 items which are used in conjunction with the door operators but which are manufactured or supplied by third parties. Such items shall carry the warranties / guarantees offered by said third parties.

7 QUALIFICATIONS

In order to qualify for the "3 Year Extended Life" Warranty offer the following criteria shall apply:-

- 7.1 the doors must be less than 12 months old at the time of installation of the operator. Proof of the age of the door is required, (e.g. an invoice from the door supplier).
- 7.2 This "3 Year Extended Life" Warranty is applicable to new "pro-alpha 2000" door operators.
- 7.3 To qualify for the "3 Year Extended Life" Warranty option it is necessary to register your ownership of the operator by filling out the Registration Card attached and mail it directly to Brano.
- 7.4 All information detailed must be supplied.
- 7.5 Subject to all conditions being met, your "pro-alpha 2000" garage door operator will then be covered

against sub-standard manufacturing workmanship and faulty components for a period not exceeding 3 years from the date of purchase.

8 VALIDITY of WARRANTY OFFER :-

The validity of the warranty is conditional upon the ownership of the door operator being registered with Brano.

Doors such as Sectional type and Spring-Pantograph Tip-Up type doors qualify for coverage under this warranty. In every instance the installation of the door operator shall be strictly in accordance with the prescribed installation instructions.

A period of 60, (sixty), days from the date of purchase / installation of the garage door operator shall be allowed for the purpose of registering ownership. Proof of date of purchase is required.

9 REGISTRATION CARD:-

The attached registration card is to be filled out and returned to Brano. Be sure to record all the information requested:-

9.1 The operator's serial number.

9.2 The date of installation.

9.3 If applicable, the type of door adaptor kit installed, e.g. "Pro-Rola 1" system or "Side-mount" system.

9.4 The Type of garage door you own and the date the door was purchased.

9.5 The Name of your Dealer / Installer.

10 ACCEPTANCE OF EXTENDED WARRANTY:-

No extended warranty shall be deemed to exist unless all the information stipulated is supplied.

11 CORRESPONDENCE:-

Always state the operator's Serial Number in any correspondence relating to warranty claims.

12 WARRANTED COMPONENTS:-

12.1 Brano warrants that all mechanical and electrical components of the "pro-alpha 2000" garage door operator which are supplied as part of the basic kit are free of defect with respect to the quality of the materials and components used as well as the quality of the manufacturing and assembly workmanship

Components include the:-

Electric motor, "worm-screw", aluminium housing, P.C. control card, attachment brackets and towing arms.

12.2 Important Note:-

The Traveller Assembly and motor-shaft coupling are designed to be "sacrificial" wearing parts and will not be considered as faulty components. They are therefore not covered by this warranty.

They are designed to "fail first" in order to protect more expensive and "difficult-to-replace" components. If one of these components fails, it is a sure sign that there is a fault somewhere in the system. Most likely the garage door is out of balance or some component of the door system is malfunctioning or is damaged and requires attention.

13 EXCLUSIONS:-

The following components, services and work are specifically excluded from the Scope of this Warranty, whether specifically stated or implied. This Warranty is invalid for the repair or replacement of Door Operating Equipment and Components which are :-

13.1 not supplied by Brano.

13 EXCLUSIONS:-

13.2 damaged by an act of G_D, (e.g. lightning strike, flood, fire, power surge, etc., etc.)

13.3 damaged due to misuse or abuse of the equipment, as when installing the operator on doors which are not suited to conversion to automatic operation, (e.g. "Tip-In" doors or "Vertical Track" type doors which have not been fitted with an approved type of Door Adaptor Kit).

13.4 used for purposes other than that for which it has been designed, (e.g. for the automation of driveway gates). The "pro-alpha 2000" door operator is not designed to operate in areas where it will be exposed to the elements.

..... It is not weatherproof !!!

13.5 used to operate doors which are not in good working order, (e.g. doors which are improperly balanced or are in a state of disrepair).

14.6 installed on doors which have to cater for very high traffic flows, (i.e. more than 10 cycles per day). The equipment is designed for, and intended to be used in, a domestic environment .

13.7 damaged due to malicious causes or sabotage.

13.8 damaged due to faulty or incorrect installation techniques and substandard workmanship, (e.g. non standard or improper wiring work, incorrect fitting of the operator and / or door adaptor and conversion kits).

13.9 damaged or have their settings disturbed due to tampering with the equipment by unqualified persons.

13.10 damaged due to fair wear and tear which is not attributable to the fault of the company, (e.g. replacement of batteries and light bulbs, traveller nuts, and other "sacrificial" wearing parts).

14 MAINTENANCE OF THE GARAGE DOOR.

It is, furthermore, a condition of this warranty that the garage door itself be maintained in a serviceable condition in accordance with the door manufacturer's instructions and as specified in the relevant sections of this "Owner's Operating Manual" and SABS - IEC 60335 - 2.

Proof of service to the doors may be required.

15 DEFECTIVE PARTS:-

Faulty components shall be repaired or replaced at the sole discretion of Brano. Defective parts replaced shall become the property of Brano.

16 COSTS INCURRED FOR SERVICE LABOUR, TRANSPORT / POSTAGE and TRAVELLING:-

Brano will be liable for the cost of the replacement parts only ! That is, the cost of specialised labour and the cost of travelling to and from site and the cost of transport or postage of spare parts are specifically excluded from the scope of this warranty. The faulty component or door operator must be returned either to Brano or to one of its authorised Distributors for repair or replacement. The cost incurred for such returns shall be for the account of the owner or installer.

17 CANCELLATION of WARRANTY.

In the event of any of these conditions being breached, Brano reserves the right to cancel the warranty with immediate effect.

Revised :- October 2001

