

SDO4 GARAGE DOOR OPERATOR INSTALLATION MANUAL



Company profile



**In-house
R&D
development
team**



**Manufacture to
international
quality standard
ISO 9001:2008**

**100%
testing of
products**

**After-sales
multi-language
Technical Support
from 07h00 to 18h00
UTC+2
Monday to Friday**



**Sales and technical support
to Africa, Europe, Asia,
the Americas, Australia
and the Pacific**

Centurion Systems (Pty) Ltd reserves the right to make changes to the products described in this manual without notice and without obligation to notify any persons of any such revisions or changes. Additionally, **Centurion Systems (Pty) Ltd** makes no representations or warranties with respect to this manual. No part of this document may be copied, stored in a retrieval system or transmitted in any form or by any means electronic, mechanical, optical or photographic, without the express prior written consent of **Centurion Systems (Pty) Ltd**.



Contents

SAFETY FIRST	IMPORTANT SAFETY INSTRUCTIONS	page 5
1. General description		page 8
2. Specifications		page 8
2.1. Physical dimensions		page 8
2.2. Technical specifications		page 9
2.3. Fuse protection		page 9
3. Product identification		page 10
3.1. Fasteners list and spares		page 11
4. Required tools and equipment		page 11
5. Preparation of site		page 12
6. Operator installation		page 13
6.1. Assembly instructions		page 13
6.2. Installation instructions		page 16
6.2.1. Sectional doors		page 16
6.2.2. Tip-up doors		page 28
6.3. Engaging and disengaging the motor		page 40
6.4. Emergency lock functionality		page 40
6.5. Positioning the opening and closing limit stoppers		page 41
6.6. The wireless wall switch		page 42
6.7. Safety beams		page 43
6.8. Connecting to a power supply		page 44
6.9. Defaulting the SDO4		page 44
7. Electrical setup		page 45
7.1. Wiring safety beams / photocells		page 45
7.2. Wiring external radio receivers		page 46
8. Commissioning the system		page 47
8.1. Control box		page 47
8.2. Selecting the door type		page 47

8.3.	Setting the limits	page 48
9.	Programming / deleting remote controls	page 50
10.	SDO4 features	page 54
11.	Troubleshooting guide	page 58
12.	24 Month product warranty	page 59
13.	Installation handover	page 60

Icons used in this manual



This icon indicates tips and other information that could be useful during the installation.



This icon denotes variations and other aspects that should be considered during installation.



This icon indicates warning, caution or attention! Please take special note of critical aspects that MUST be adhered to in order to prevent injury.

IMPORTANT SAFETY INSTRUCTIONS

ATTENTION

To ensure the safety of people and possessions, it is important that you read all the following instructions.

Incorrect installation or incorrect use of the product could cause serious harm to people and / or property.



The installer, being either professional or DIY, is the last person on the site who can ensure that the operator is safely installed, and that the whole system can be operated safely.

Warnings for the installer

CAREFULLY READ AND FOLLOW ALL INSTRUCTIONS before beginning to install the product.

- The installation of your new **SDO4** must be carried out by a technically qualified or licensed person. Attempting to install or repair the **SDO4** without suitable technical qualification may result in severe personal injury, death and / or property damage
- The **SDO4** must only be installed on a properly-balanced, well-functioning garage door. The garage door is deemed to be well-balanced and aligned if it:
 - Requires an equivalent amount of applied force to either manually open or close. The applied force should not exceed 100N (10kg)
 - Does not rise or fall more than 100mm when released at any point between the fully open and fully closed positions
 - Does not rub on or incorrectly make contact with any supporting or surrounding structures
 - The horizontal tracks have been installed level, and
 - The door panels have been installed level, and
 - The vertical tracks have been installed plumb, and
 - The junction between the curved horizontal track and the vertical track does not cause the door to 'jump'
- The counterbalance springs on sectional type garage doors must be properly lubricated between all of the coils with heavy automotive bearing grease
- Failure to adequately lubricate the springs may result in one or more of the following:
 - Counterbalance springs may become rusty over time, resulting in additional operating friction between the coils which may cause the **SDO4** to malfunction
 - Seasonal temperature changes may cause the garage door springs to expand and / or contract. The resultant increase and / or decrease in operating friction may cause the **SDO4** to malfunction. Properly lubricating the springs will help to minimise changes in operating friction due to the effects of seasonal temperature change

- Repairs to the garage door must be carried out by technically qualified persons. Attempting to repair the garage door without suitable technical qualification may result in severe personal injury, death and / or property damage
- Where possible, install the **SDO4** at least two meters or more above the ground. Adjust the engage / disengage cord so that it hangs approximately 1.8 meters from the ground
- The header bracket carries ALL of the opening and closing thrust of the **SDO4** and as such must be securely fastened to a rigid, structural member of the garage wall or ceiling. It is entirely up to the installer to determine the fixing method and the structural suitability of the fixing points
- The engage / disengage instruction tag must remain attached to the engage / disengage cord
- Locate the wall switch;
 - within site of the garage door, and
 - at a minimum height of 1.5 meters above the ground so that it remains out of the reach of small children, and
 - away from all moving parts of the garage door
- The entrapment warning label must be secured in a prominent position adjacent to the wall switch
- Do not connect the **SDO4** to the power outlet until this manual instructs you to do so
- Subsequent to installation and adjustment, the **SDO4** must stop and reverse direction when it comes into contact with a 35mm high solid object placed on the floor under the garage door
- The correct function of the safety obstruction force system should be checked on a monthly basis
- Never use the **SDO4** unless the garage door is in full view and free from any object which may impede the movement of the garage door such as cars, children and / or adults
- Never allow children to operate the **SDO4**
- Never operate the **SDO4** when any persons are under or near the path of the garage door. Children must be supervised at all times when near the garage door and when the **SDO4** is in use
- Never attempt to disengage the **SDO4** to manual operation when there are children/ persons and / or solid objects including motor vehicles under or near the path of the garage door as the garage door may fall sharply upon Manual Release from the **SDO4**
- Never attempt to open or close the garage door by pulling on the engage / disengage cord
- Never attempt to make any repairs or remove covers from the **SDO4** without first disconnecting the power supply cord from the main power supply
- Removal of the **SDO4**'s protective covers must only be performed by a technically qualified person. Attempting to remove the protective covers or repair the **SDO4** without suitable technical qualification may result in severe personal injury, death and/or property damage

- For additional safety we strongly recommend the inclusion of safety beams. Although the **SDO4** incorporates a pressure sensitive safety obstruction force system, the addition of safety beams will greatly enhance the operating safety of an automatic garage door and provide additional peace of mind. In some countries it is a mandate of law to fit safety beams. It is the sole responsibility of the owner / installer to fit safety beams in those countries that so require
- Always ensure that the garage door is fully open and stationary before driving in or out of the garage
- Always ensure the garage door is fully closed and stationary before moving out of its view
- Adjustments to the safety stop / reverse force settings must only be carried out by a technically qualified person. Attempting to adjust the settings without suitable technical qualification may result in severe personal injury, death and / or property damage
- Keep hands and loose clothing clear of the **SDO4** and garage door at all times
- In order for the safety obstruction force system to function, it must first encounter an obstruction in the form of an object / person onto which some force **MUST** be exerted. As a result, the object / person / garage door may suffer **DAMAGE AND / OR INJURY**
- The safety obstruction system is designed to work on **STATIONARY** objects only. Serious personal injury, death and / or property damage may occur if the garage door comes into contact with a moving object during an open or close cycle





Please note that images in this installation manual are not to scale.

1. General Description

The **SD04** has been designed to automate domestic garage doors safely, quietly and reliably. The product's chain-driven system allows for whisper-quiet operation, while reliable battery backup ensures that the **SD04** will continue working even during lengthy power outages. In addition, the **SD04's** built-in collision sensing circuitry makes it a very safe automation solution. Kits are available for both sectional and tip-up garage doors.

2. Specifications

2.1. Physical dimensions

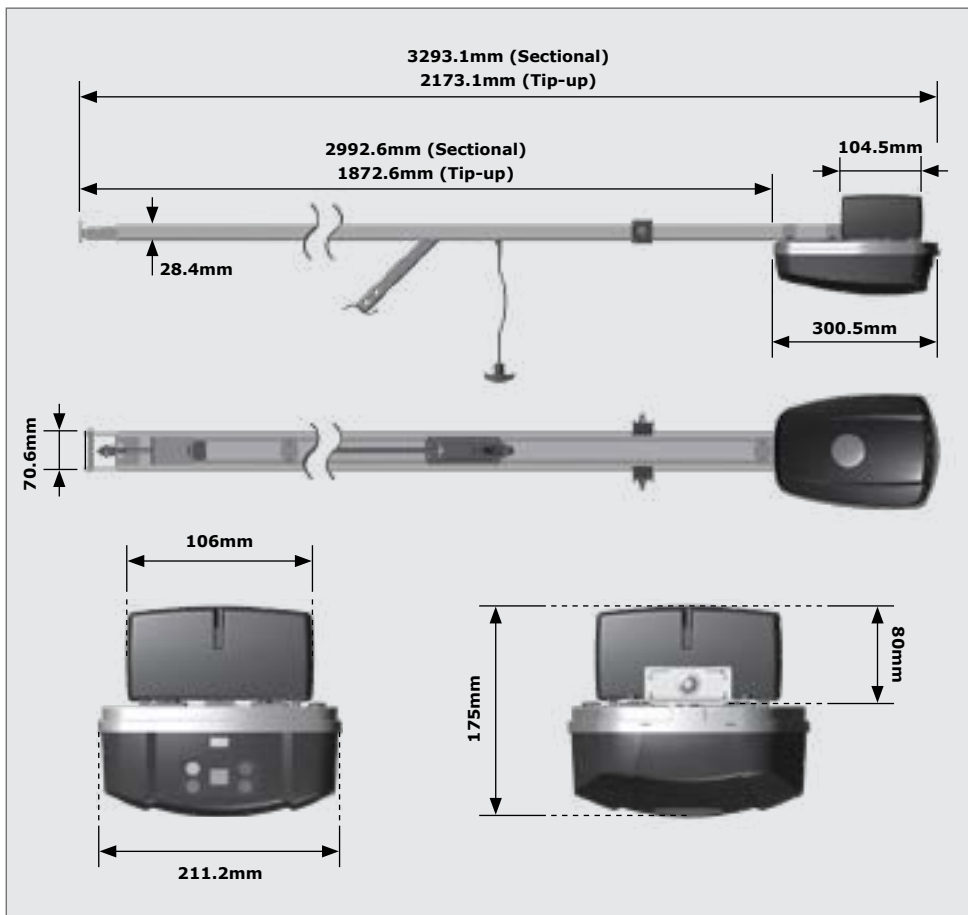

FIGURE 1. OVERALL DIMENSIONS FOR THE SD04

2.2. Technical specifications

	T10	T12
Input voltage	230V AC @ 50/60Hz ¹	
Motor voltage	24V DC	
Motor power - rated	80W DC	100W DC
Motor supply	Battery supply 2 x 3.4 Ah 24 V DC	Battery supply 2 x 3.4 Ah 24 V DC
Max door width	6500mm	
Max door area	12m ²	15m ²
Max lifting capacity	1000N	1200N
Operations in standby mode	12 to 30 depending on the door size / weight / height / duration of power failure / condition of batteries	12 to 30 depending on the door size / weight / height / duration of power failure / condition of batteries
Operator travel speed	Tip-up: 80mm/sec. Sectional: 140mm/sec with fully charged batteries.	
Door travel adjustment	Physical Endstops (Automatic limit set)	
Safety obstruction force system	Built-in menu	
Light	LED 2W	
Autoclose ²	Menu Selectable	
Infrared safety beams	Menu Selectable. (Optional, but recommended)	
Radio receiver	Code-hopping 433MHz	
Receiver code storage capacity	20 transmitters (consisting of four buttons each)	

1: Can operate off a solar supply, please consult Centurion Systems (Pty) Ltd for assistance

2: Requires infrared safety beams to be fitted

TABLE 1

2.3. Fuse protection

The following protection fuses are provided on the system:

Item	Type	Rating
Main controller		
Motor circuit	ATO	15A

TABLE 2

3. Product Identification

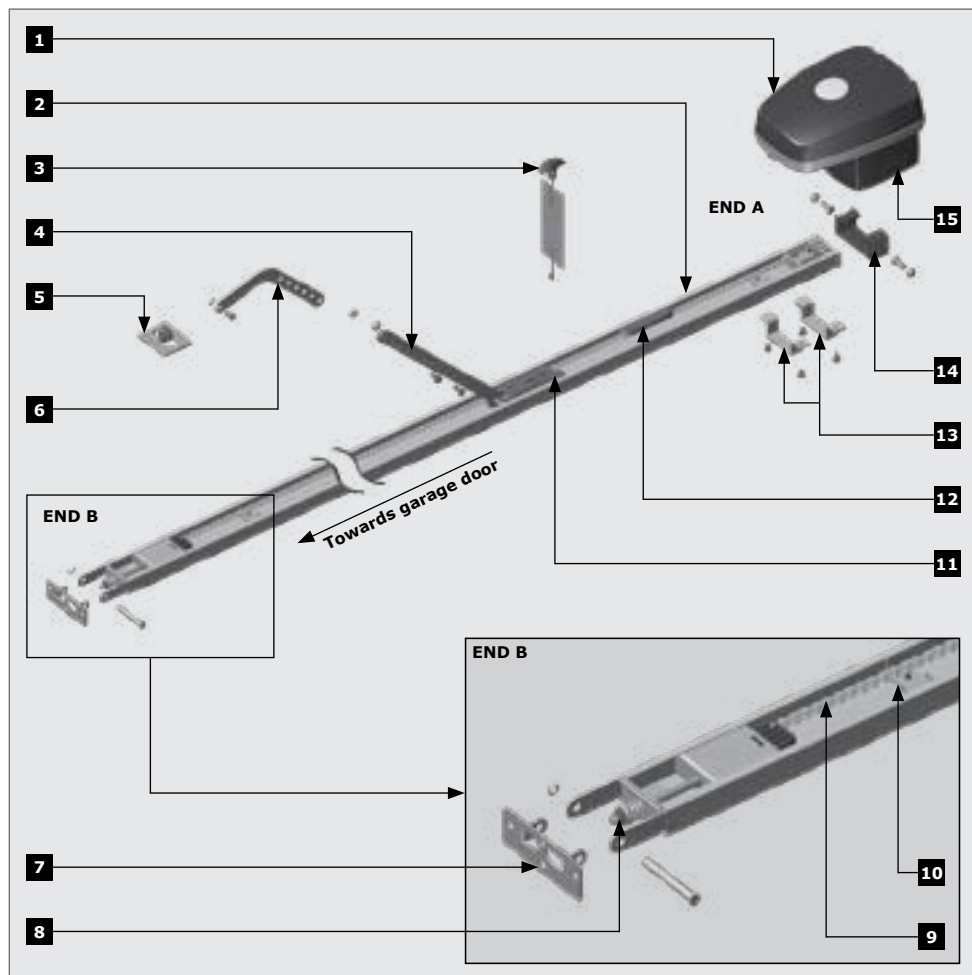

FIGURE 2. PRODUCT IDENTIFICATION

- | | |
|------------------------------|------------------------|
| 1. Control head unit | 9. Drive chain |
| 2. Rail | 10. End stop |
| 3. Release handle | 11. Carriage |
| 4. Straight towing arm | 12. Chain bullet |
| 5. Towing bracket | 13. Head unit brackets |
| 6. Bent towing arm | 14. Rail hanger |
| 7. Header bracket | 15. Battery housing |
| 8. Tensioning nut and spring | |

3.1. Fasteners list and spares

Description	QTY
ST5.5 x 50 Self-tapping Coach Screws	4
ST8 x 60 Self-tapping Screws	3
ST6.3 x 25 Self-tapping Screws - Hex Flange Head	3
M6 x 8 Black Cross Pan Head Screws	2
M8 x 20 Hexagon Head Bolts	6
M6 x 12 Black Wizzlock Bolts	4

Description	QTY
M8 Wizzlock Nuts	8
Ø8 x 71 Clevice Pin	1
Ø8 x 18 Black Clevice Pin	1
Ø2 Hairpin Clips	2
12 x 60mm Fischer Plugs	3
M8 x 25(Pitch 1.25) Black Gutter Bolts	2

TABLE 3

4. Required Tools and Equipment

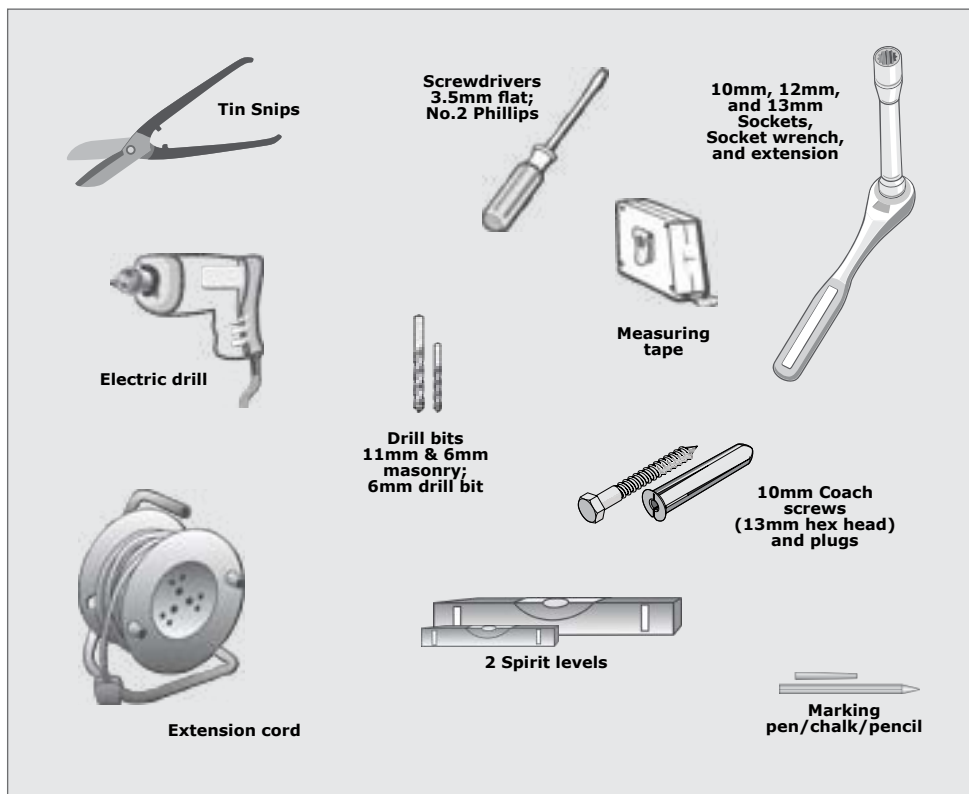

FIGURE 3. REQUIRED TOOLS AND EQUIPMENT

5. Preparation of Site

5.1. General consideration for the installation

Always recommend the fitment of additional safety equipment such as safety edges and safety beams, for additional protection against entrapment or other mechanical risks.

Ensure that no pipes or electrical cables are in the way of the intended installation.

Install the garage operator only if:

- It will not pose a hazard to the public
- The installation will meet all municipal and/or local authority requirements once completed
- The door mass and application is within the operator specifications
- There is a properly-earthed general purpose 220-240V AC power outlet that has been installed by a qualified electrical contractor
- All locks, ropes and / or securing mechanisms have been removed
- The ceiling structure is adequate enough to support the weight of the **SDO4**
- The garage door is in good working order, meaning:
 - it opens freely;
 - it is well-balanced;



An improperly-balanced or malfunctioning garage door could cause serious personal injury, death and / or property damage. Have a qualified person check and, if required, make repairs to the garage door before installing the **SDO4**.

- it does not move on its own if left in any position for more than 100mm;
- it can be installed to have sufficient clearance between moving parts when opening or closing to reduce the risk of personal injury and / or entrapment



Any repairs to the garage door that need to be done due to any of the above requirements not being in place, must be carried out by technically qualified persons.



Attempting to repair the garage door without suitable technical qualifications, may result in severe personal injury, death, and / or property damage.

6. Operator Installation

6.1. Assembly instructions

6.1.1. Identify the garage door type

Identify the garage door type and then select the preferred installation method and assembly type that is best-suited to the application.

Sectional doors

- Use a 3000mm one-piece drive rail
- The standard 3000mm drive rail will lift a door up to 2440mm high. (An optional drive rail extension kit is available for doors over 2440mm high)
- The **SDO4** is supported by the drive rail hanger which is hung from the ceiling using appropriate hanging material
- The drive rail must be parallel with the ceiling as shown in Figure 4.
- The header bracket may be mounted on the front wall of the garage or on the ceiling adjacent to the front wall

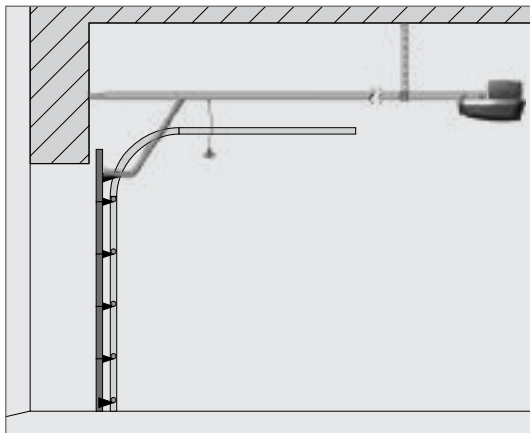

FIGURE 4

Tip-Up doors

- Use a 2000mm one-piece drive rail
- The **SDO4** is supported by the drive rail hanger which is hung from the ceiling using appropriate hanging material
- The drive rail must be angled, so that the pivot points at each end of the connecting arm should be as close to horizontal as possible when the door is in the fully open position
- The header bracket may be mounted on the front wall of the garage or on the ceiling adjacent to the front wall

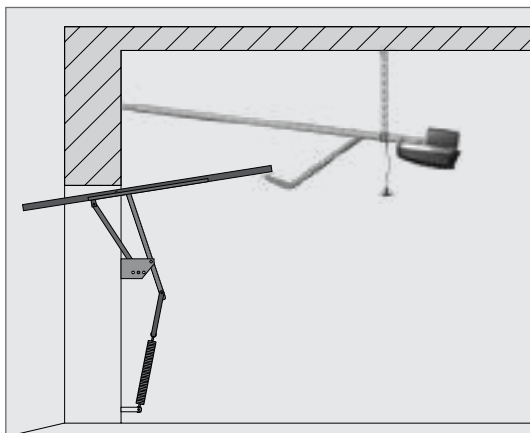

FIGURE 5

6.1.2. General assembly

Open the packing carton and expose the **SDO4** components.

Orientate the drive rail so that the terminal bracket faces towards the garage door

1. Fit the M8 black gutter bolts onto the drive rail hanger. Secure them using the supplied M8 nuts. This must be done before fitting the drive rail hanger onto the Drive Rail.
Fit the Drive Rail hanger and slide it down the Drive Rail starting from 'End A' (Figure 6).

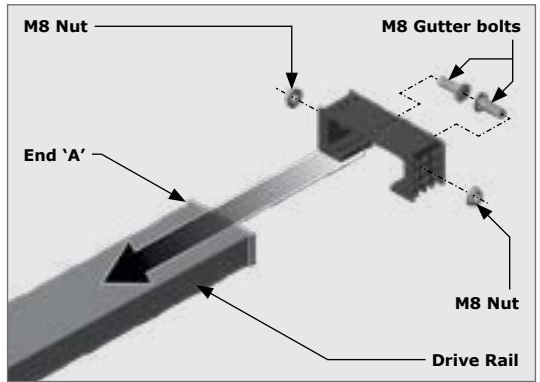

FIGURE 6

It is important at this point of the installation to open the battery housing (Refer back to Figure 2), and connect the batteries before continuing with the installation.

2. Orientate the Drive Rail as shown in Figure 7, and fit 'End A' over the motor coupling found on the motor.

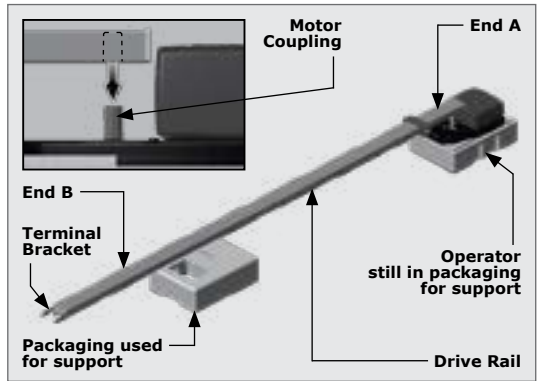

FIGURE 7



Keep the operator in its packaging for support, and use the other half of the packaging to support the other end of the Drive Rail.



FIGURE 8

3. Swing the track from side to side should the motor coupling struggle to engage with the shaft. **DO NOT** exceed 25° in either direction.

4. Place the two U-Brackets into position over the four holes found on the head unit (Figure 9).
5. Secure the U-Brackets into position using 4x black M6x12mm screws supplied (Figure 10).

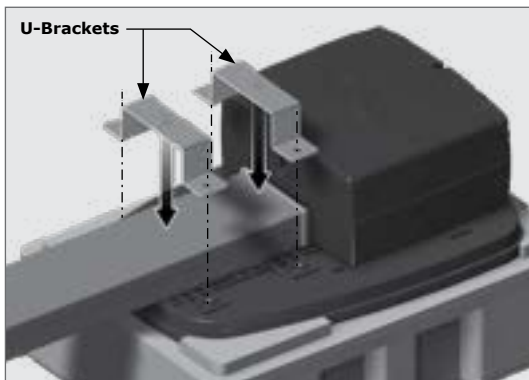

FIGURE 9

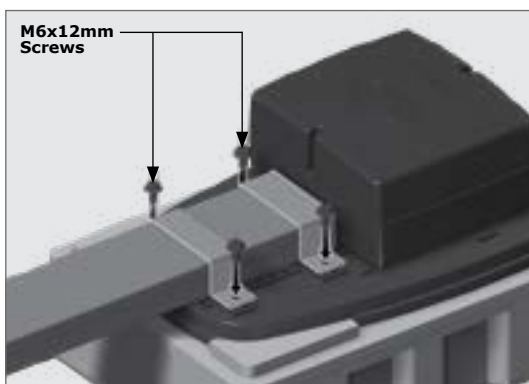

FIGURE 10

6.1.3. Tensioning the chain

The chain comes pre-tensioned from the factory; however, ensure that the spaces between the spring windings are 0.5-1mm. Use a 13mm socket wrench to tighten the drive should there, for whatever reason, be a deviation from these values.

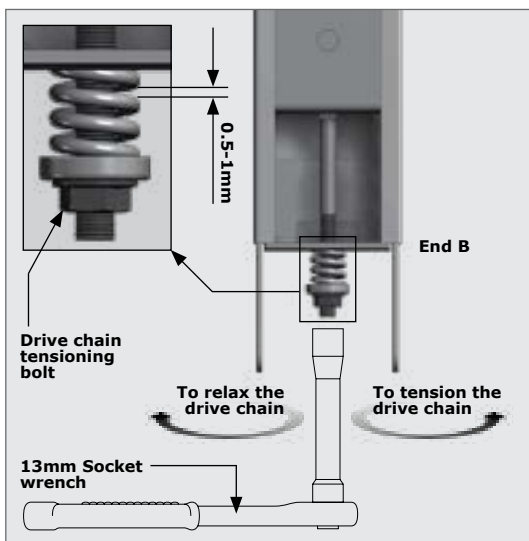

FIGURE 11

6.2. Installation instructions

6.2.1. Sectional doors (For Tip-up doors skip to Section 6.2.2)



Before commencing the installation, ensure that you have carefully read and understood all safety recommendations. In particular, ensure that the installation of the garage door complies with the requirements specified. Make any necessary adjustments to the garage door **BEFORE** commencing the installation!

Important considerations to note before commencing installation



- The opening heights are **2135mm** for standard doors, or **2540mm** for caravan height doors
- The structure is level, square and plumb
- For sectional doors, the door panel overlaps the opening by no more than 30mm at the top, and sides.

Door traveling path

The travel path of a garage door is determined by the path the top section of the garage door takes as the door is being opened or closed.

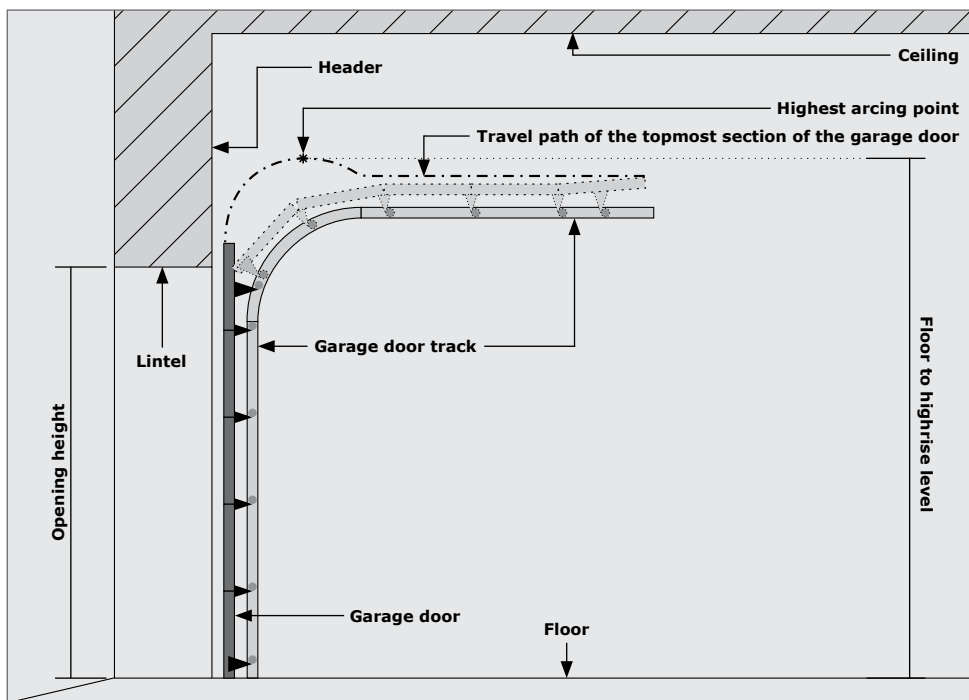

FIGURE 12

6.2.1.1. Mounting the header bracket



The header bracket carries ALL of the opening and closing thrust of the SDO4 and as such must be securely fastened to a rigid, structural member of the garage. It is entirely up to the installer to determine the fixing method and the structural suitability of the fixing points.



When marking important lines needed for mounting the header bracket, ensure that a spirit level is used, as it is imperative that these lines are as level and straight as possible.

Determine the highest arcing point of the garage door and mark this as a horizontal line on the header above the top edge of the garage door.

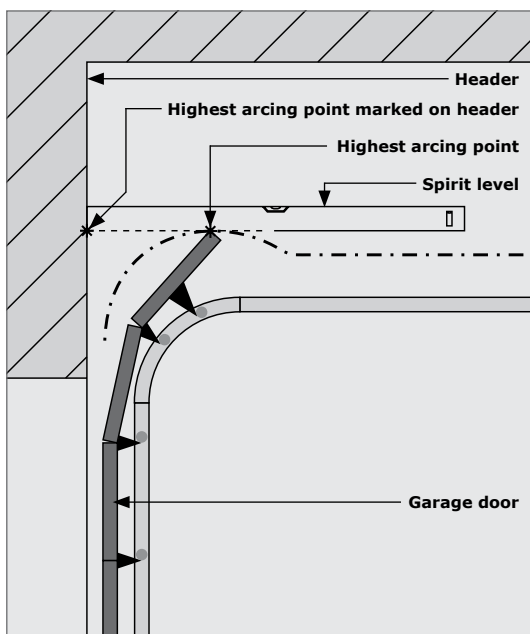

FIGURE 13

Close the garage door, and determine the garage door center line and mark a vertical line on the header above the door.

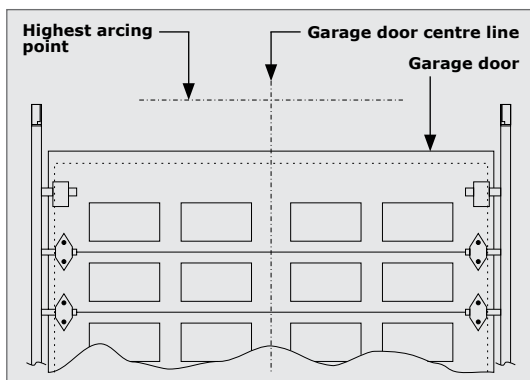

FIGURE 14

Place the header bracket on the wall as shown in Figure 15. Ensure that the **bottom edge** of the bracket is level, and **no more than 50mm above** the highest arcing point of the garage door. Mark the location of the four screw holes (Hole A, B, C and D[optional]).



Note the orientation of the header bracket.



Mounting the drive rail more than 50mm above the highest arcing point of the garage door may cause the drive rail to flex excessively.

Drill four 11mm diameter holes in position of 'Hole A', 'Hole B', 'Hole C' and 'Hole D'(optional), at least 50mm deep.

Place a fischer plug in each hole, followed by the header bracket. Secure it in position with at least three coach screws (supplied) (13mm hexagonal head).

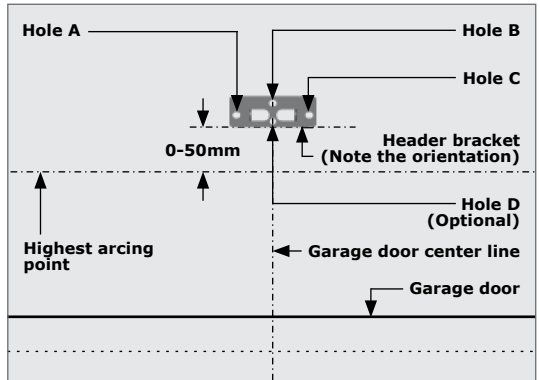

FIGURE 15

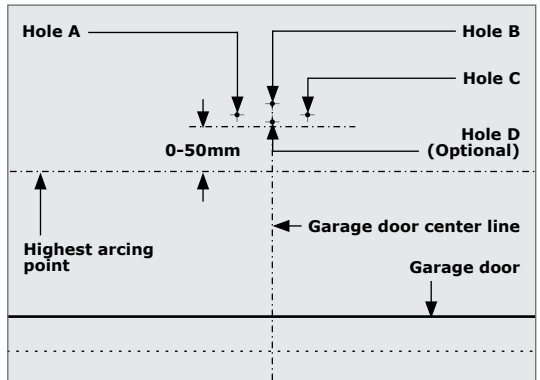

FIGURE 16

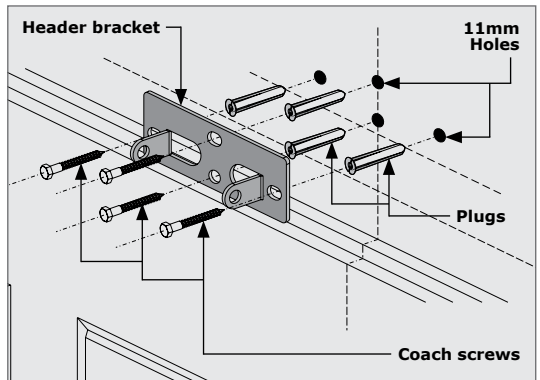

FIGURE 17



If after securing the header bracket, it is slightly out (not level), use a hammer to knock the tabs gently up or down with a small spirit level placed on top of them. This will ensure a perfectly level installation (Figure 18).

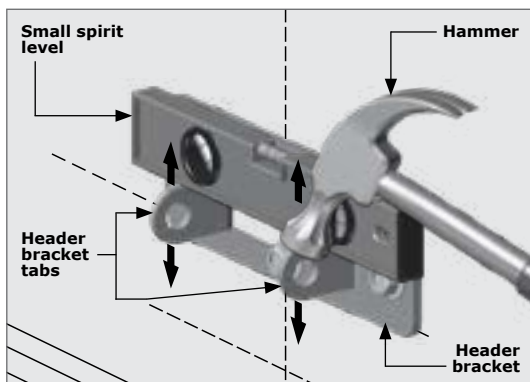

FIGURE 18

6.2.1.2. Mounting the SDO4 to the header bracket



It is important at this point of the installation to ensure that the batteries are connected before continuing with the installation.

Position the **SDO4** in place, with the open end of the drive rail facing the floor, and the tensioning bracket towards the garage door. You will need a second person to assist you with this.

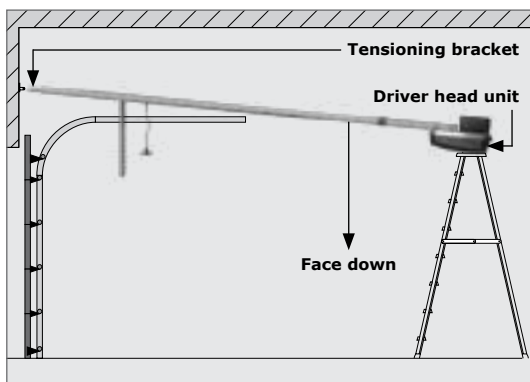

FIGURE 19



If you are on your own, use a ladder to support the control unit end of the **SDO4** while you are positioning it for the next step (Figure 19).

Align the holes on the side of the tensioning bracket with the holes of the header bracket.

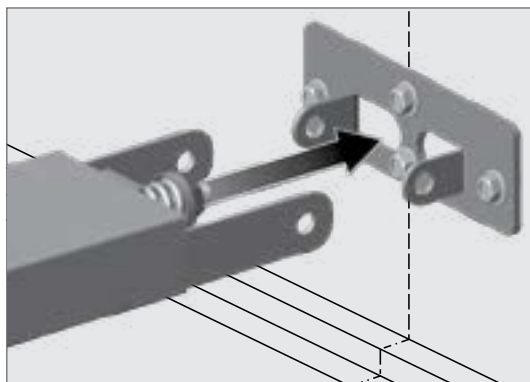

FIGURE 20

Locate the long clevis pin through the holes and secure it into position with a supplied Circle Clip on the other end of the clevis pin.



Dowel split pins have also been supplied should they be preferred over the use of the circle pin clips.

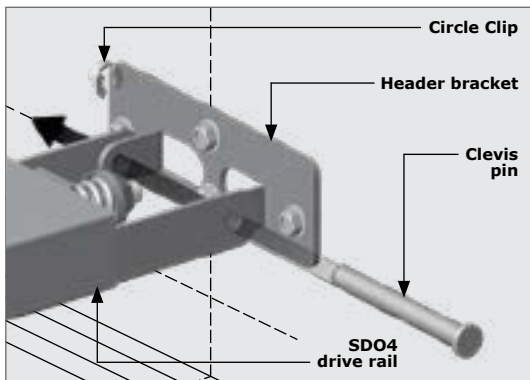

FIGURE 21

6.2.1.3. Mounting the SDO4 drive rail to the ceiling

Open the garage door, and gently rest the **SDO4** on top of the open door.



If your ladder is high enough, we recommend resting it on top of the ladder.

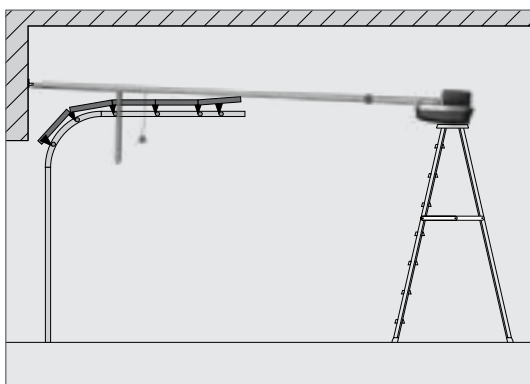

FIGURE 22

Find the centre line of the garage door, and mark it on the ceiling above the location of the drive rail hanger.



You can use the **SDO4** drive rail as a gauge to assist you if needed.

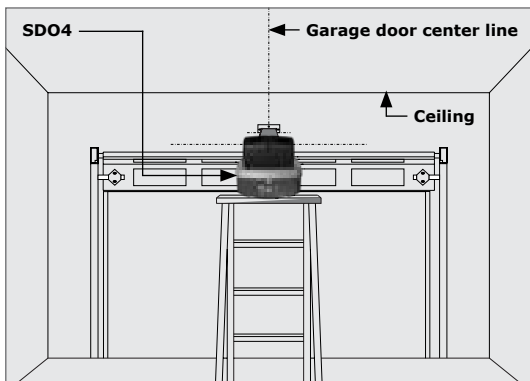

FIGURE 23

Use a long spirit level along the length of the **SDO4** drive rail, and level out the **SDO4**, so that it is running parallel to the ceiling.

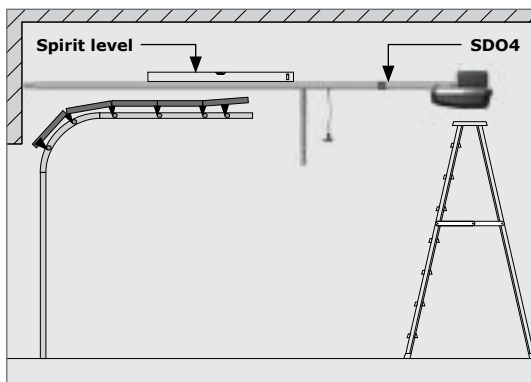

FIGURE 24

Place another spirit level perpendicular to the ceiling, and line it up with the center of the drive rail hanger bolt on the side of the drive rail hanger. Make a mark on the ceiling, and repeat this for the other side of the drive rail hanger.

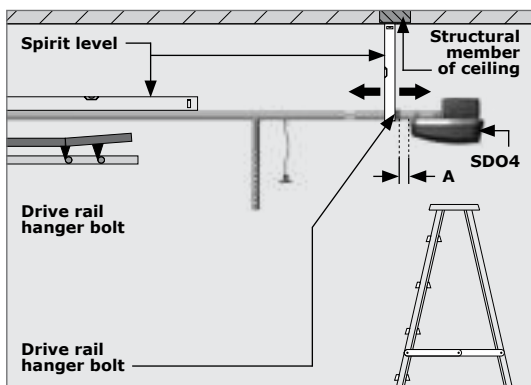

FIGURE 25

Ensure that the drive rail hanger bracket is positioned directly under a **strong** structural member of the ceiling. If it is not, move it along the drive rail to a suitable position before marking it off on the ceiling.



We recommend that the maximum cantilever distance between the hanger bracket and the front edge of the control unit should not exceed 300mm. (Marked as 'A' in Figure 25)



Draw a line on the ceiling joining these two marks, perpendicular to the garage door center line made earlier.

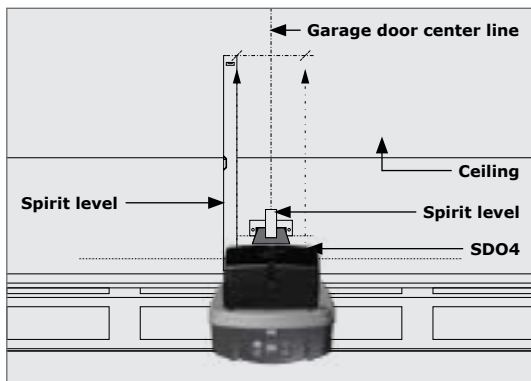

FIGURE 26

Measure and cut a 150mm length of punched angle iron with a pair of tin snips.



Snip off the four corners of the punched angle iron to add a degree of safety and neatness to the installation.

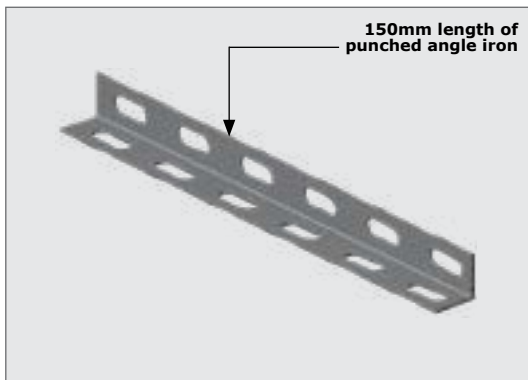

FIGURE 27

Align the punched angle iron centered onto the garage door centre line, and the perpendicular line running along the center of the horizontal face holes.

The horizontal face must face the back of the garage. Secure the punched angle iron to the ceiling with suitable screws (depending on the structural member of the ceiling).



Ensure that the punched angle iron is mounted to a strong structural member in the ceiling.

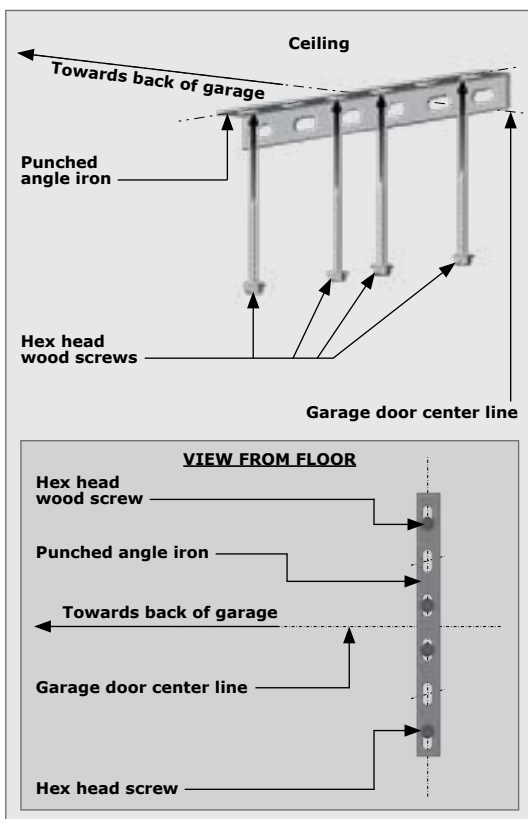

FIGURE 28

Level the **SDO4** again, and measure the length needed from the ceiling to the underside of the drive rail, marked as 'Value Xmm' in Figure 29.

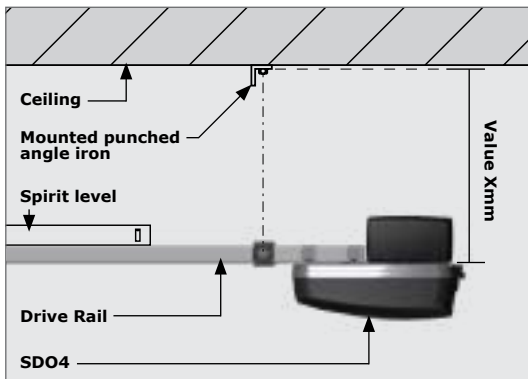

FIGURE 29

Using an angle grinder or hack saw, cut two lengths of punched angle iron to the measurement taken for 'Value Xmm'.



Snip off the four corners of the punched angle iron to add a degree of safety and neatness to the installation.

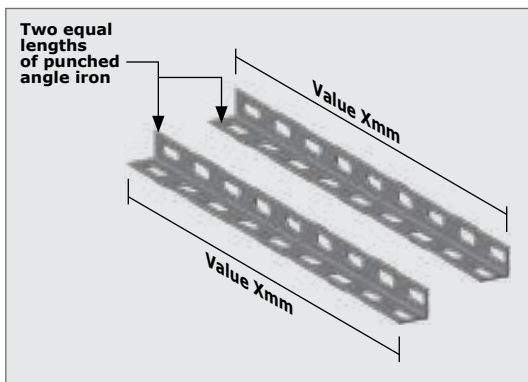

FIGURE 30

Remove the two drive rail hanger nuts from the bolts, and locate the two lengths of punched angle iron into position as shown in Figure 31. Secure them in position with the two drive rail hanger nuts.



Ensure that the punched angle iron does not protrude further than the SDO4 drive rail base, as this will interfere with the operation of the motor!

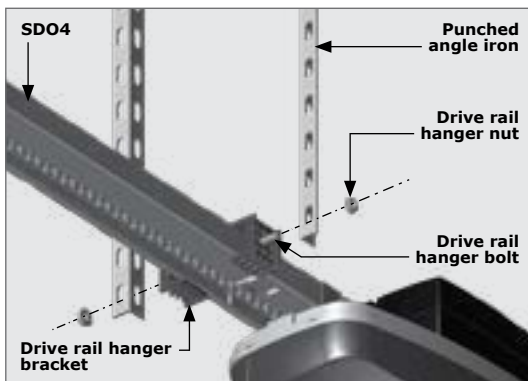

FIGURE 31

Use a spirit level to ensure that the **SDO4** is still level and parallel to the ceiling. Align the holes of the punched angle iron mounted to the ceiling, with the holes on the punched angle iron mounted to the drive rail hanger. Secure it into position using two supplied M8 flange bolts and nuts using a 13mm socket.

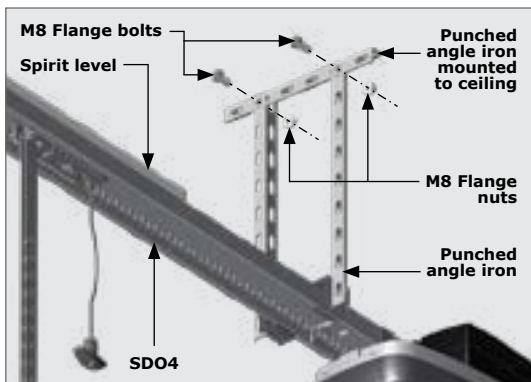

FIGURE 32



Using a spirit level, ensure that the **SDO4** is level on both the X-Axis and Z-Axis of the horizontal plain. If it is not, it may cause the motor to stress, or the drive rail to twist.

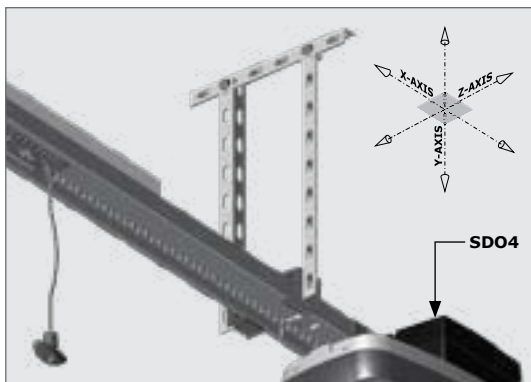

FIGURE 33

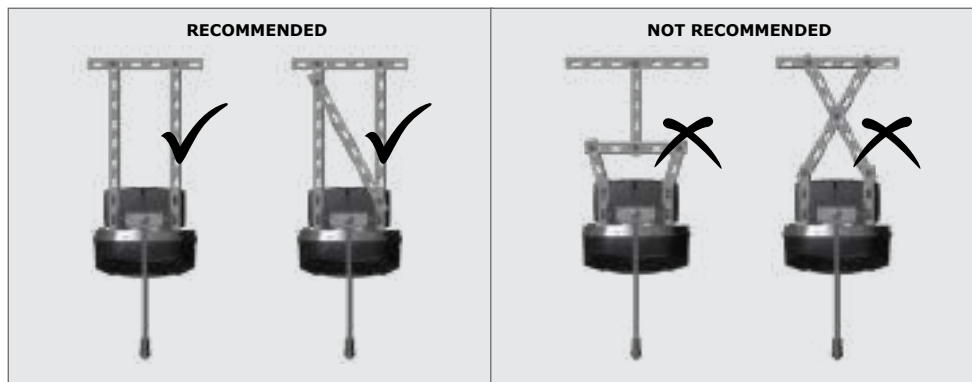

FIGURE 34. CORRECT AND INCORRECT MOUNTING CONFIGURATIONS FOR THE SDO4

6.2.1.4. Mounting the towing bracket to the garage door.

Close the garage door, and find its center line. Make a level mark perpendicular to the garage door center line, and in line with the top edge of the top roller of the garage door.

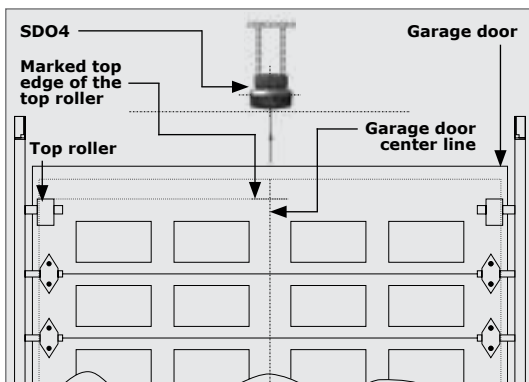

FIGURE 35

Center the towing bracket on the garage door center line and so that the center of the two holes on the protruding tabs are in line with the top edge of the top roller.



Place a small spirit level on the top edge of the towing bracket, to ensure that it is level when drilling holes.

Secure the towing bracket into position using the three hexagonal head self-tapping screws supplied.

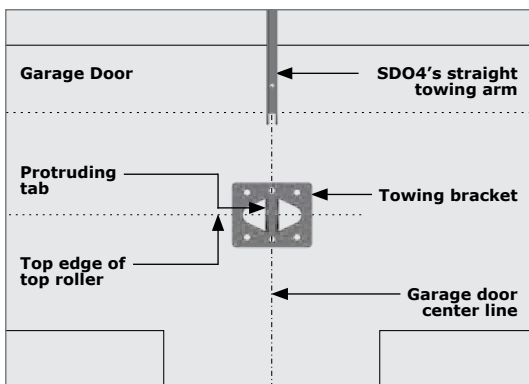

FIGURE 36



If the garage door is heavier than average, more screws can be used to fix the bracket to the garage door.



Ensure that the length of the screws do not exceed the depth of the garage door.



The above method is for the purpose of wooden garage doors. Should you have a garage door that is not constructed from wood, such as a steel garage door, we recommend the use of TEK® screws to secure the towing bracket to the garage door.

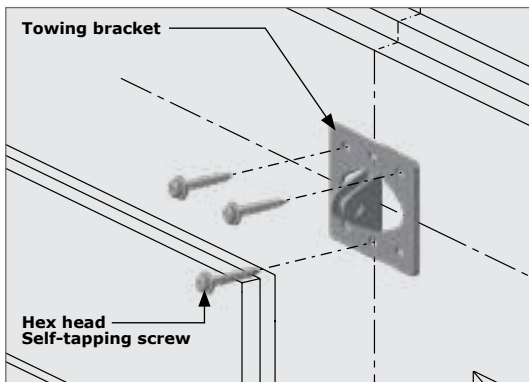

FIGURE 37

6.2.1.4. Fitting the bent towing arm to the towing bracket and straight towing arm.

Slot the bent towing arm between the two protruding tabs of the towing bracket, and align the holes. Note the orientation of the bent towing arm.

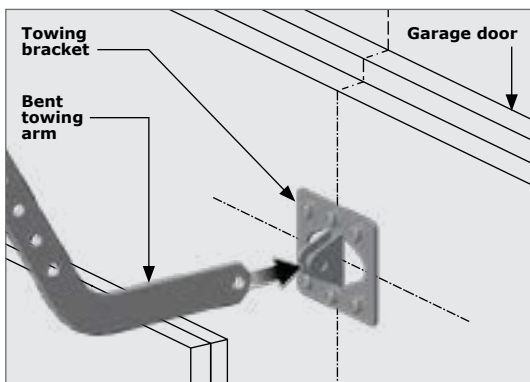

FIGURE 38

Locate the short clevis pin through the holes and secure it into position with a supplied Circle Clip on the other end of the clevis pin.



Dowel split pins have also been supplied should they be preferred over the use of the circle pin clips.

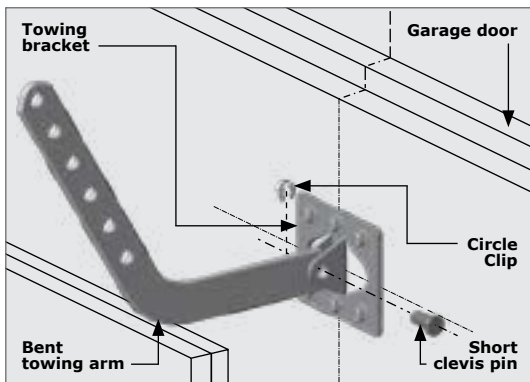

FIGURE 39

Slot the bent towing arm into the straight towing arm, and align the holes. If they do not align, move the carriage up or down the drive rail in order to align the holes of the bent and straight towing arms.



Ensure that the two towing arms overlap by at least two holes. This will ensure a strong join, and prevent the arm from swiveling whilst the motor is in operation.

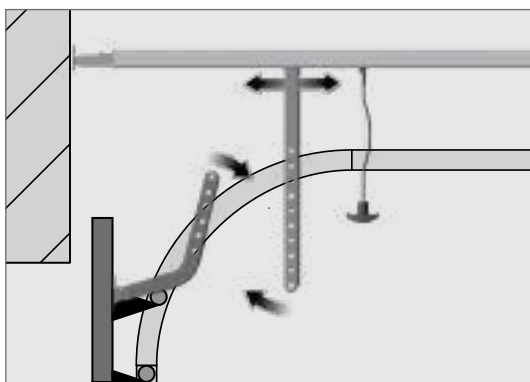

FIGURE 40

The two towing arms must be joined in such a way that they are just short of parallel to the garage door and the ceiling.

Angle 'Z' should be $\pm 80^\circ$ when the garage door is in the closed position, as shown in Figure 41.

This will put less strain on the motor on start-up and, furthermore, aid in preventing the garage door from being forced open by hand.

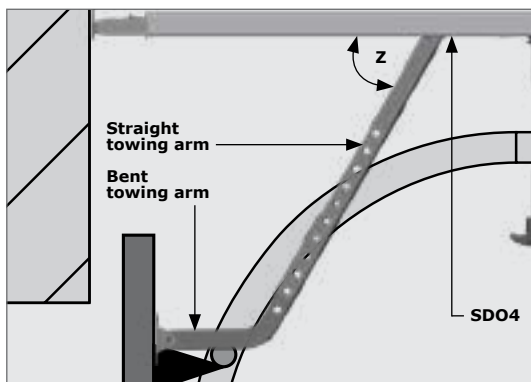

FIGURE 41

Once aligned, secure the towing arms into position using the two supplied hexagonal head flange nuts and bolts: one set through the bottom hole of the straight towing arm, and the other through the top hole of the bent towing arm.

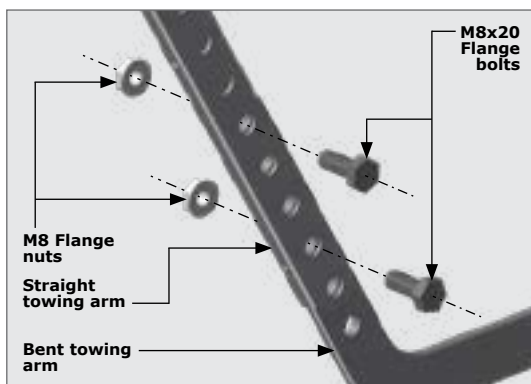

FIGURE 42

Please do not forget to affix the safety sticker and tag.



The **SDO4** is now installed and ready for programming.

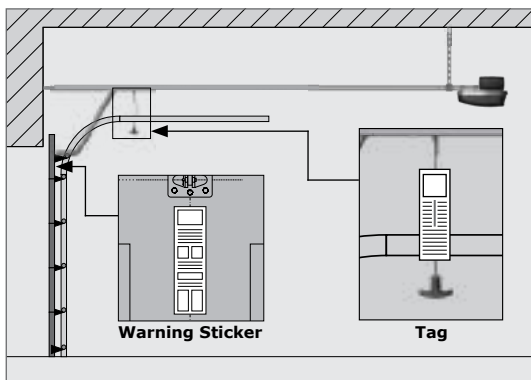

FIGURE 43

6.2.2. Tip-up doors



Before commencing the installation, ensure that you have carefully read and understood all safety recommendations. In particular, ensure that the installation of the garage door complies with the requirements specified. Make any necessary adjustments to the garage door BEFORE commencing the installation!

Important considerations to note before commencing installation



- The opening heights are **2135mm** for standard doors
- The structure is level, square and plumb

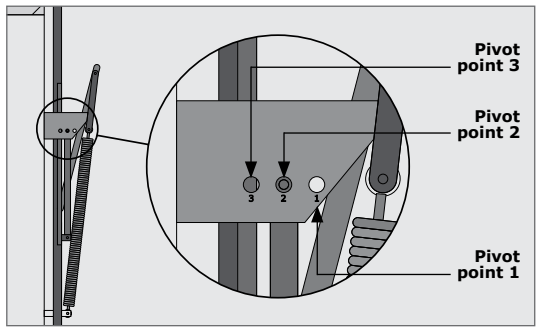

FIGURE 44

- Pivot position No. 1 or 2 (140mm or more head room) is recommended for automation. If insufficient headroom is available, contact an approved garage door installer to assist with possible modifications

Door traveling path

The travel path of a garage door is determined by the path that the top section of the garage door takes as the door is being opened or closed.

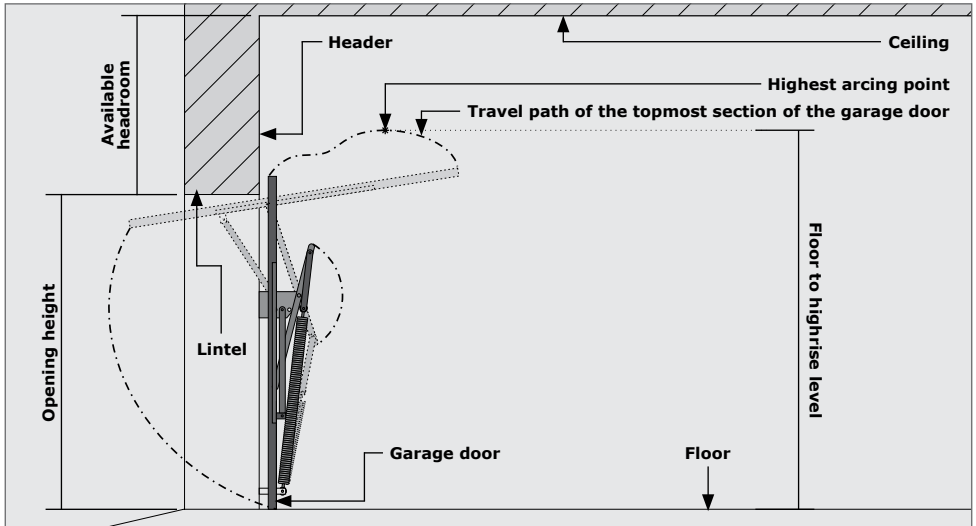

FIGURE 45

6.2.2.1. Mounting the header bracket



The header bracket carries ALL of the opening and closing thrust of the SDO4 and as such must be securely fastened to a rigid, structural member of the garage. It is entirely up to the installer to determine the fixing method and the structural suitability of the fixing points.



When marking important lines needed for mounting the header bracket, ensure that a spirit level is used, as it is imperative that these lines are as level and straight as possible.

Determine the highest arcing point of the garage door and mark this as a horizontal line on the header above the top edge of the garage door.

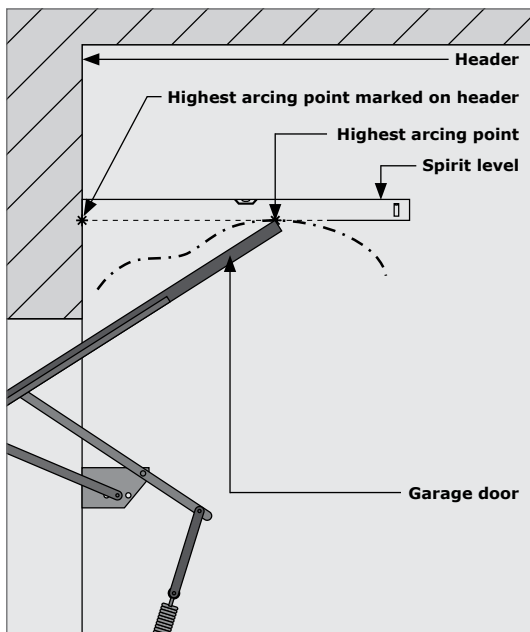

FIGURE 46

Close the garage door, and determine the garage door center line and mark a vertical line on the header above the door.

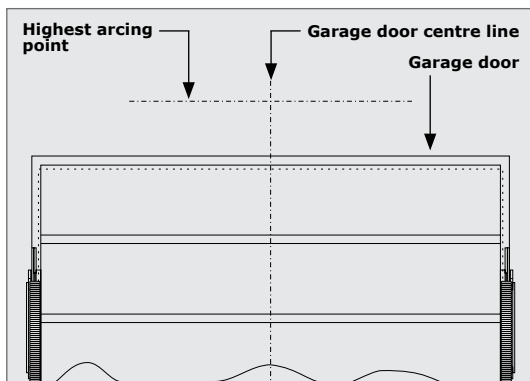

FIGURE 47

Place the header bracket on the wall as shown in Figure 48. Ensure that the **bottom edge** of the bracket is level, and between 20mm - 50mm, but **no more than 50mm above** the highest arcing point of the garage door. Mark the location of the three screw holes (Hole A, B, C and D[optional]).



Note the orientation of the header bracket.



Mounting the drive rail more than 50mm above the highest arcing point of the garage door may cause the drive rail to flex excessively.

Drill four 11mm diameter holes in position of 'Hole A', 'Hole B', 'Hole C' and 'Hole D'(optional), at least 50mm deep.

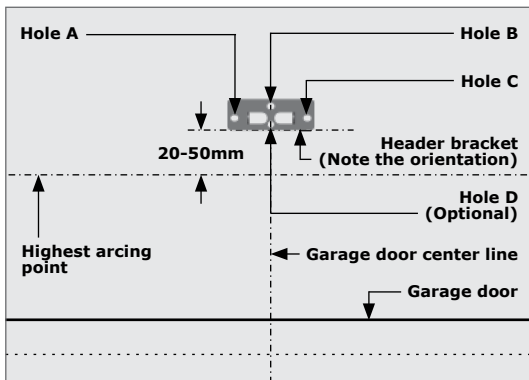

FIGURE 48

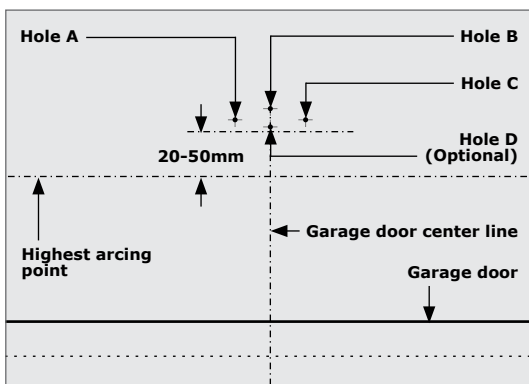

FIGURE 49

Place a fischer plug in each hole, followed by the header bracket. Secure it in position with at least three coach screws (supplied) (13mm hexagonal head).

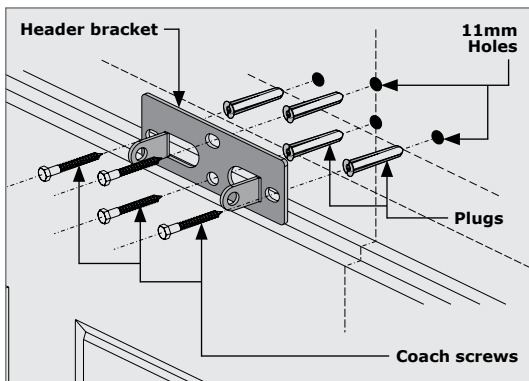

FIGURE 50



If, after securing the header bracket, it is slightly out (not level), use a hammer to knock the tabs gently up or down with a small spirit level placed on top of them. This will ensure a perfectly level installation.

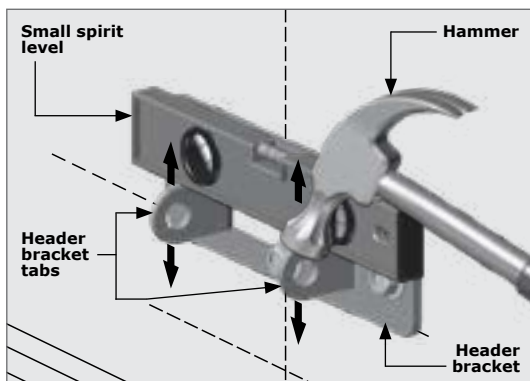

FIGURE 51

6.2.2.2. Mounting the SDO4 to the header bracket



It is important at this point of the installation to ensure that the batteries are connected before continuing with the installation.

Position the **SDO4** in place, with the open end of the drive rail facing the floor, and the tensioning bracket towards the garage door. You will need a second person to assist you with this.

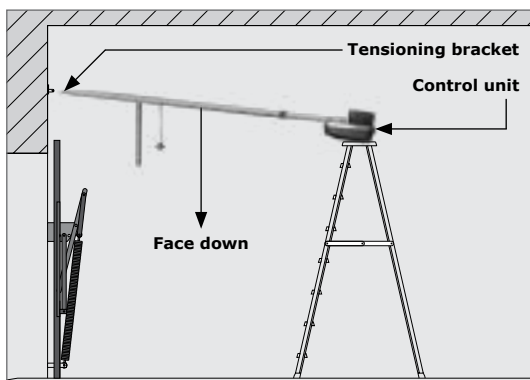

FIGURE 52



If you are on your own, use a ladder to support the control unit end of the **SDO4** while you are positioning it for the next step (Figure 52).

Align the holes on the side of the tensioning bracket with the holes of the header bracket.

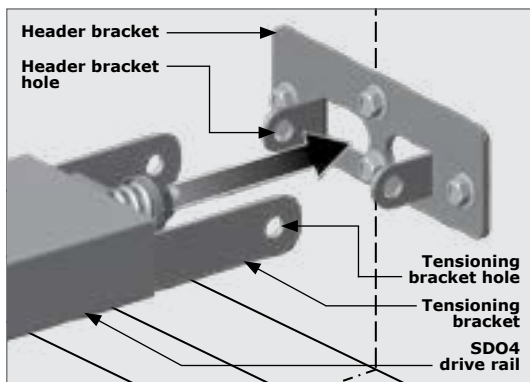

FIGURE 53

Locate the long clevis pin through the holes and secure it into position with a supplied Circle Clip on the other end of the clevis pin.



Dowel split pins have also been supplied should they be preferred over the use of the circle pin clips.

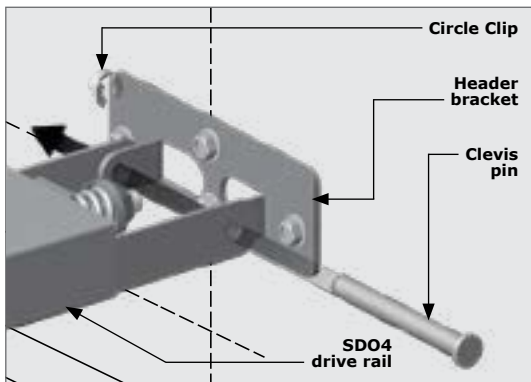

FIGURE 54

6.2.2.3. Mounting the SDO4 drive rail to the ceiling

Open the garage door, and gently rest the **SDO4** on top of the open door.



If your ladder is high enough, we recommend resting it on top of the ladder.

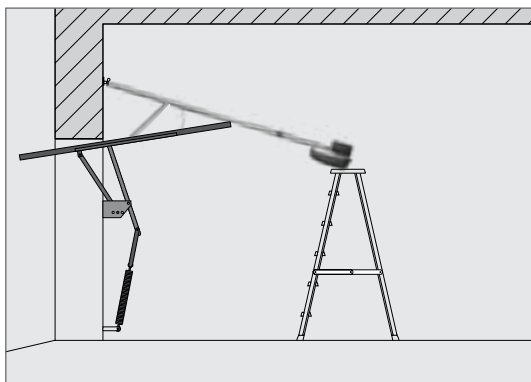

FIGURE 55

Find the center line of the garage door, and mark it on the ceiling above the location of the drive rail hanger.



You can use the **SDO4** drive rail as a gauge to assist you if necessary.

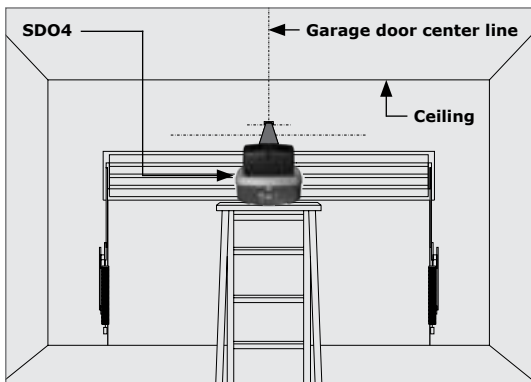

FIGURE 56

Lift the **SDO4** to a point where the control unit (Point B) is in line with the top of the open garage door (Point A).

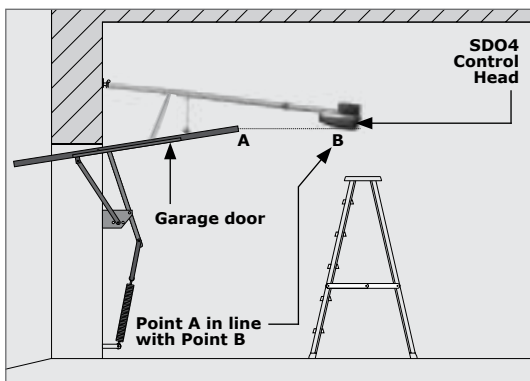

FIGURE 57

Keeping the control unit in line with the top of the garage door, place a spirit level perpendicular to the ceiling, and line it up with the center of the drive rail hanger bolt on the side of the drive rail hanger. Make a mark on the ceiling, and repeat this for the other side of the drive rail hanger.

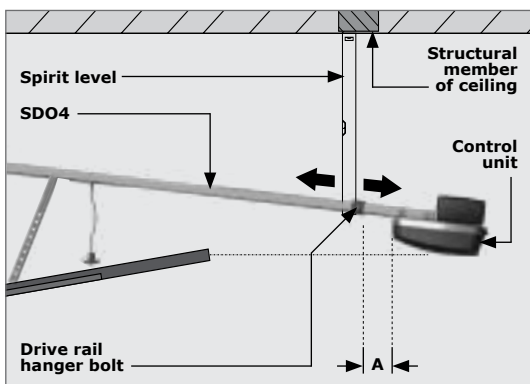

FIGURE 58

Ensure that the drive rail hanger bracket is positioned directly under a **strong** structural member of the ceiling. If it is not, move it along the drive rail to a suitable position before marking it off on the ceiling.



We recommend that the maximum cantilever distance between the hanger bracket and the front edge of the control unit does not exceed 300mm. (Marked as 'A' in Figure 58)



Draw a line on the ceiling joining these two marks, perpendicular to the garage door center line made earlier.

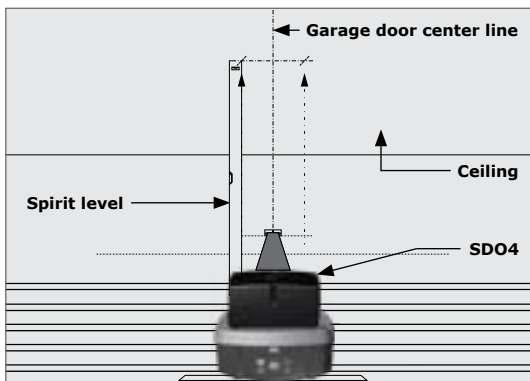

FIGURE 59

Measure and cut a 150mm length of punched angle iron with a pair of tin snips.



Snip off the four corners of the punched angle iron to add a degree of safety and neatness to the installation.

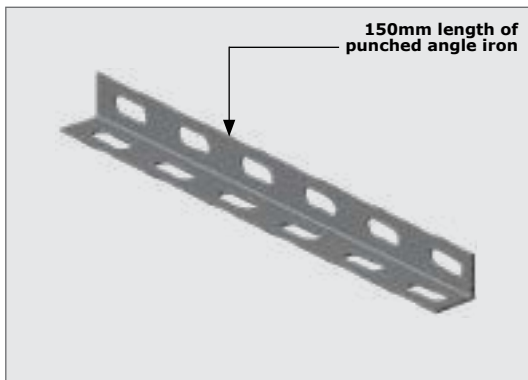

FIGURE 60

Align the punched angle iron centered onto the garage door center line, and the perpendicular line running along the centre of the horizontal face holes.

The horizontal face must face the back of the garage. Secure the punched angle iron to the ceiling with suitable screws (depending on the structural member of the ceiling).



Ensure that the punched angle iron is mounted to a strong structural member in the ceiling.

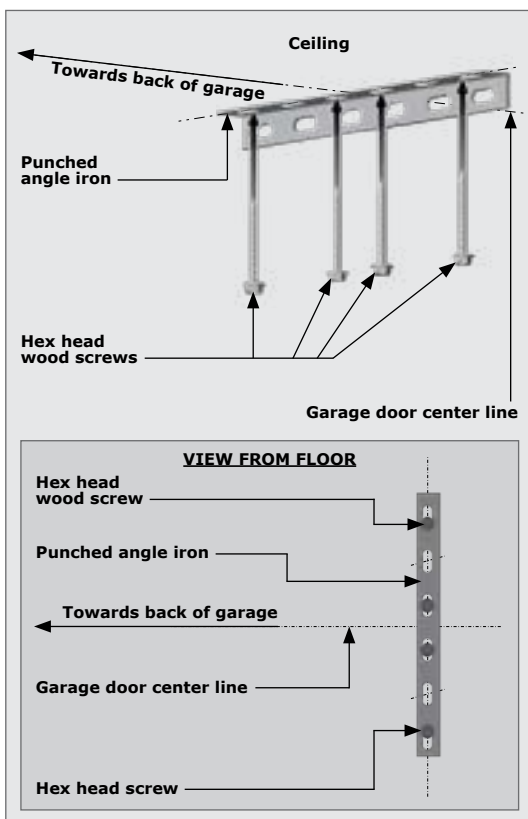

FIGURE 61

Position the **SD04** again, as shown in Figure 60, and measure the length needed from the ceiling to the underside of the drive rail, marked as 'Value Xmm' in Figure 62.

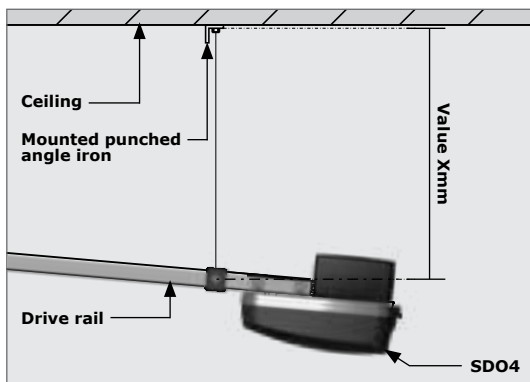

FIGURE 62

Using an angle grinder or hack saw, cut two lengths of punched angle iron to the measurement taken for 'Value Xmm'.



Snip off the four corners of the punched angle iron to add a degree of safety and neatness to the installation.

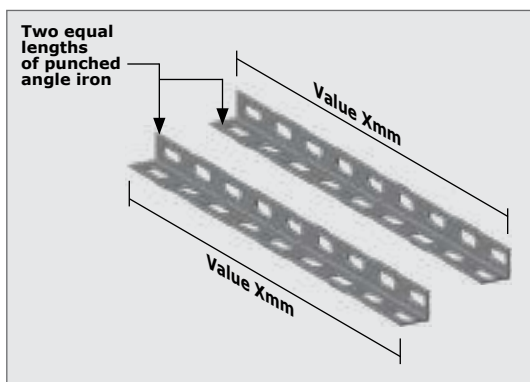

FIGURE 63

Remove the two drive rail hanger nuts from the gutter bolts, and locate the two lengths of punched angle iron into position as shown in Figure 64. Secure them in position with the two drive rail hanger nuts.

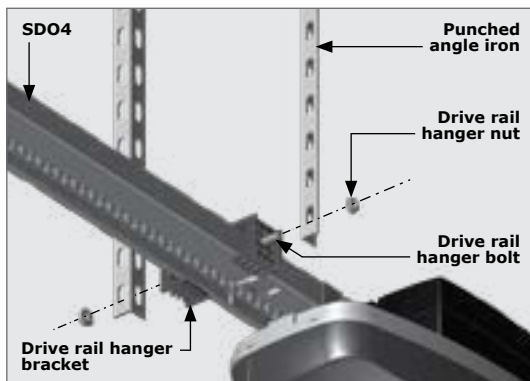

FIGURE 64

Align the holes of the punched angle iron mounted to the ceiling, with the holes on the punched angle iron mounted to the drive rail hanger. Secure it into position using two supplied M8 flange bolts and nuts with a 13mm socket.



Ensure that the **SDO4** control unit is in line with the top edge of the open garage door before tightening the bolts in their final position.

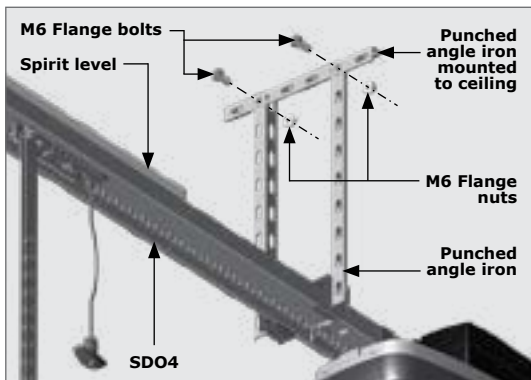

FIGURE 65

Correct and incorrect configurations for mounting the **SDO4** to the ceiling.

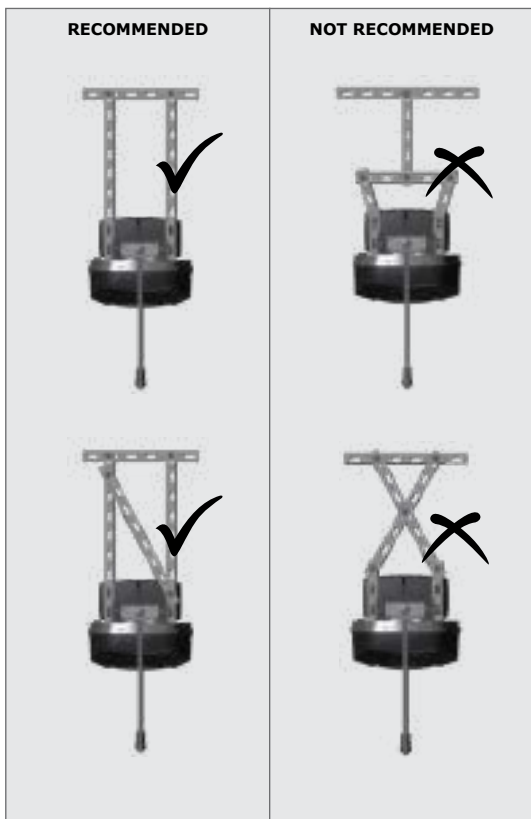

FIGURE 66

6.2.2.4. Mounting the towing bracket to the garage door.

Close the garage door, and find its center line.

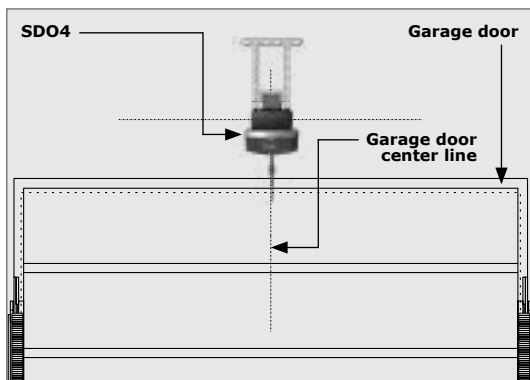

FIGURE 67

Center the towing bracket on the garage door center line and so that the top edge of the towing bracket is as close to the top edge of the garage door as possible.



Place a small spirit level on the top edge of the towing bracket, to ensure that it is level when drilling holes.

Secure the towing bracket into position using the three hexagonal head self-tapping screws supplied.

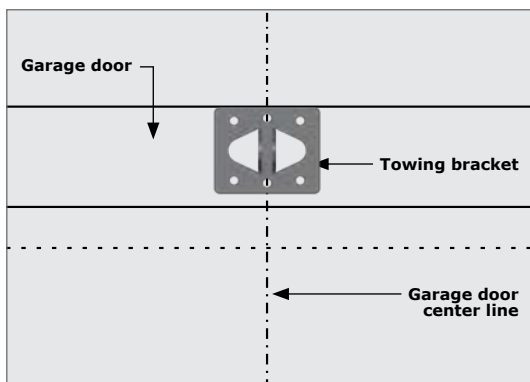

FIGURE 68

If the garage door is heavier than average, more screws can be used to fix the bracket to the garage door.



Ensure that the length of the screws do not exceed the depth of the garage door.



The above method is for the purpose of wooden garage doors. Should you have a garage door that is not constructed from wood, such as a steel garage door, we recommend the use of TEK® screws to secure the towing bracket to the garage door.

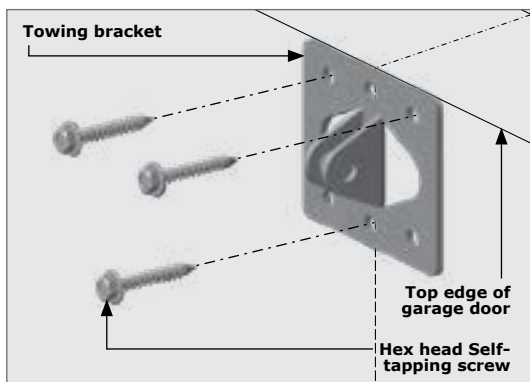

FIGURE 69

6.2.2.5. Fitting the bent towing arm to the towing bracket and straight towing arm.

Slot the bent towing arm between the two protruding tabs of the towing bracket, and align the holes. Note the orientation of the bent towing arm.

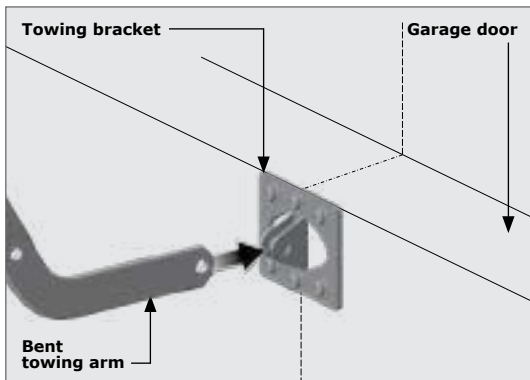

FIGURE 70

Locate the short clevis pin through the holes and secure it into position with a supplied Circle Clip on the other end of the clevis pin.



Dowel split pins have also been supplied should they be preferred over the use of the circle pin clips.

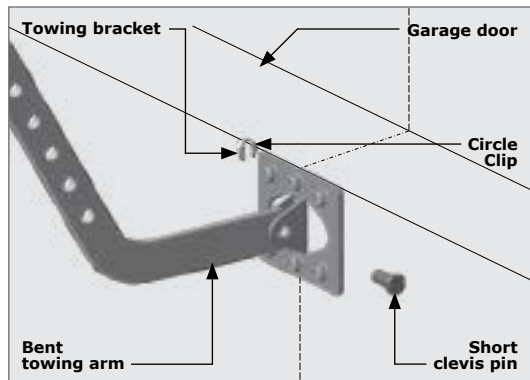

FIGURE 71

Slot the bent towing arm into the straight towing arm, and align the holes. If they do not align, move the carriage up or down the drive rail in order to align the holes of the bent and straight towing arms.



Ensure that the two towing arms overlap by at least two holes. This will ensure a strong join, and prevent the arm from swiveling whilst the motor is in operation.

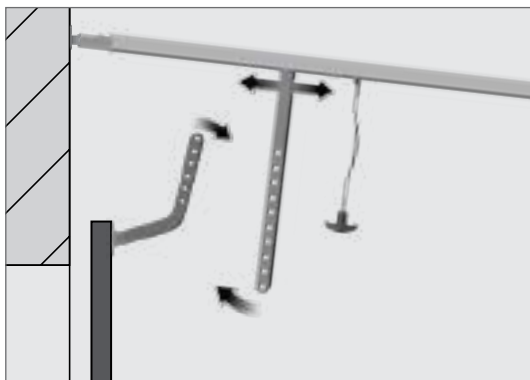

FIGURE 72

The two towing arms must be joined in such a way that they are just short of parallel to the garage door and the ceiling.

Angle 'Z' should be $\pm 80^\circ$ when the garage door is in the closed position, as shown in Figure 73.

This will put less strain on the motor on start-up and, furthermore, aid in preventing the garage door from being forced open by hand.

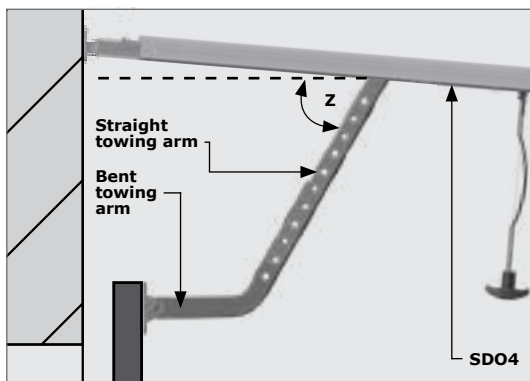

FIGURE 73

Once aligned, secure them into position using two supplied hexagonal head flange nuts and bolts: one set through the bottom hole of the straight towing arm, and the other through the top hole of the bent towing arm.

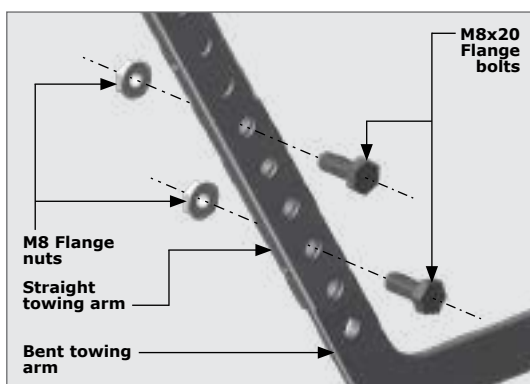

FIGURE 74

Please do not forget to affix the safety sticker and tag.



The **SD04** is now installed and ready for programming.

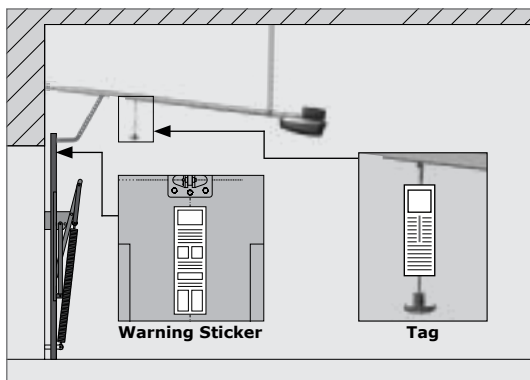

FIGURE 75

6.3. Engaging and disengaging the motor

Functionality

- TO DISENGAGE - pull down on the release handle until you hear a 'click'
 - TO ENGAGE - Pull the release handle back towards the control head until you hear a 'click', and move the carriage until it engages with the chain bullet (Figure 76)
 - **Never attempt to open or close the garage door by pulling on the release handle. Doing so may result in SERIOUS PERSONAL INJURY and / or PROPERTY DAMAGE**
- !**
- **Always disengage the SDO4 with the garage door in the fully closed position**
 - **If attempting to disengage the SDO4 from any position other than with the garage door fully closed, ensure that there are no persons and / or property near or directly under the path of the door**

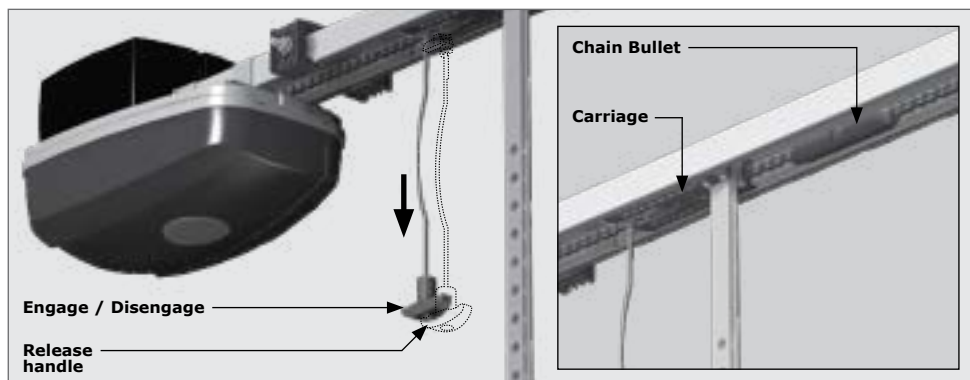

FIGURE 76

6.4. Emergency lock functionality

In the event of a system malfunction with the door in any position other than fully closed, the **SDO4** offers an emergency lock system that can be used to secure the door in the fully closed position.

In order to close and lock the door in the fully closed position, the user will need to disengage the operator using the manual release feature (see Section 6.3.).

! **If attempting to disengage the SDO4 from any position other than with the garage door fully closed, ensure that there are no persons, pets and / or property near or directly under the path of the door.**

1. Lower the door slightly by hand and re-engage the operator by pulling the manual release handle back towards the control head until you hear a 'click'.
2. Lower the door to the fully closed position.
3. Test that the door has locked in place by attempting to lift it by hand.
4. Once the system malfunction has been rectified, the system can be returned to automatic operation by disengaging the operator using the manual release feature (see Section 6.3.).

5. Open the door slightly by hand and re-engage the operator by pulling the manual release handle back towards the control head until you hear a 'click'.
6. Raise the door slowly to the fully open position until it engages with the bullet. A click will be heard as it engages.
7. The door is now ready for normal operation.

6.5. Positioning the opening and closing end-stops

The drive rail-mounted end-stops provide a one-to-one ratio between end stop movement and garage door movement, thereby ensuring 100% accuracy and ease of adjustment. Fully open and fully closed positions of the garage door can be easily adjusted by moving the end-stops to the desired location in order to increase or decrease garage door travel.

6.5.1. Positioning the closing end-stop

- Ensure that the motor is disengaged
- Close the garage door fully
- Locate the closing end-stop within the drive rail - nearest to the front wall of the garage
- Position the end-stop 10mm away from the carriage, then tighten the two lock screws



If grub screws are not securely tightened, the end-stops will fail during setup.



The grub screws will slightly dent the rail when tightened correctly.

6.5.2. Positioning the opening end-stop

- Ensure that the motor is disengaged
- Open the garage door fully
- Locate the opening end-stop within the drive rail - nearest to the back wall of the garage
- Position the end-stop 10mm away from the carriage, then tighten the two lock screws
- Re-engage the motor

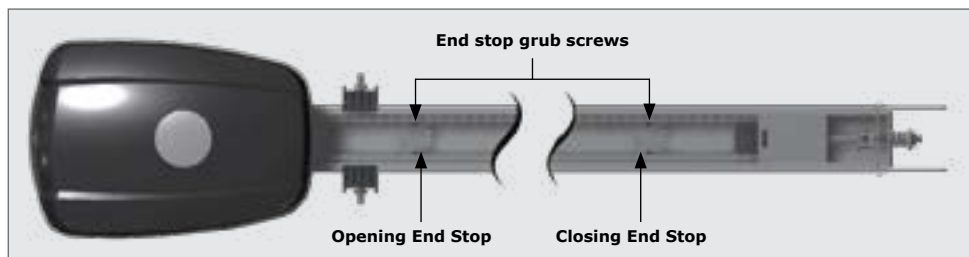

FIGURE 77



The closing and opening end-stops work on a one-to-one ratio with the garage door, meaning that, if the limit prong is moved by 10mm, then the garage door will also move by 10mm.

6.6. The wireless wall switch

The wireless wall switch provided with the **SDO4** kit (T12 Model only) provides ease of installation, obviating the need for running hard wires to the switch. It can be mounted in a convenient location such as adjacent to a side entry door into the garage. The four buttons provided on the wall switch are for independently operating from one wall switch, the two openers of a double garage door installation. The buttons can be used for activating the various functions provided by the system.

Each individual button of the wall switch has been marked with a number, from one to four, to help the user identify which function each button operates. The buttons can be learned in any configuration.



The wireless wall switch must be mounted within sight of the garage door and a reasonable distance away from moving parts. It should be mounted at least 1500mm above the ground and the entrapment warning label provided, must be attached adjacent to the switch.

Mounting

- The switch can be permanently screwed to the wall through the mounting holes provided or alternatively 'hooked' on the wall, providing the convenience of easy demount ability, through the 'hook' holes provided on the base cover
- To permanently mount the unit, open it, and place the back panel of the unit in the desired position on the wall



Take care not to damage the electronics when opening and handling the unit.

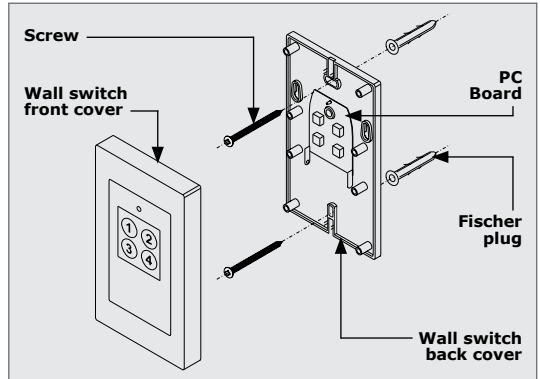

FIGURE 78

- Place a small spirit level on the top of the back panel to ensure that the unit will be level once mounted. Using a marking pen, mark the drill holes on the wall
- Drill two 6mm holes
- Locate two fischer plugs into the holes
- Align the back panel holes with the holes in the wall, and secure it into position using two screws
- Insert the battery, and replace the front cover
- The wireless wall switch may be learned into the **SDO4's** memory as per the procedure outlined in Section 9

6.7. Safety beams

- The Photon or other two- and four-wire safety beams may be connected to the **SDO4**
- The installation of safety beams greatly enhances safety by constantly monitoring for persons or objects which may pass within the path of the moving garage door
- The **SDO4** will safety reverse if the safety beams become momentarily or permanently interrupted during a closing cycle

6.7.1. Two-wire safety beams

6.7.1.1. Mounting

1. Locate the Safety Beam mounting brackets provided.
2. Mark the inside garage door framing so that the bottom edge of the mounting bracket sits 125mm off the floor.
3. Use the two mounting screws provided to fasten each mounting bracket to the wall.
4. Use the two screws and nuts provided to fasten the Safety Beams to the mounting brackets so that the indicator lamp on each Safety Beam is facing upwards. (Refer to installation instructions for further information)

6.7.1.2. Connection

- Strip back and connect the two strands of one end of the cable to each of the two terminals located on the outer cover of each safety beam
- Fix the cable securely up and along the wall, and run one length of each cable adjacent to the control box
- Strip back and connect one strand of each cable to the output terminals 'SB' and place the jumper onto '2W'. Refer to Section 7 - "Electrical setup of accessories"

6.7.2. Four-wire safety beams

6.7.2.1. Mounting

1. Mark the inside garage door framing so that the bottom edge of the beam sits 125mm off the floor.
2. Using a small angle bracket, fasten each beam to the wall so that they face each other across the garage door (Refer to installation instructions for further information).

6.7.2.2. Connection

Follow the Safety beam instructions and connect to the output terminals. Use the normally-closed contacts of the beam to connect to input 'SB' on the **SDO4** and place the jumper on '4W'. Refer to Section 7 - "Electrical setup of accessories".



The **SDO4** provides a 24V DC output and normally-closed input for safety beams.



For aligning and testing the safety beams, please refer to the installation manual supplied with the respective safety beams used.

6.8. Connecting to a power supply

- Plug the **SDO4** into a properly-earthed 220 to 240V AC power outlet
- Ensure that no excess power cord hangs below the control box

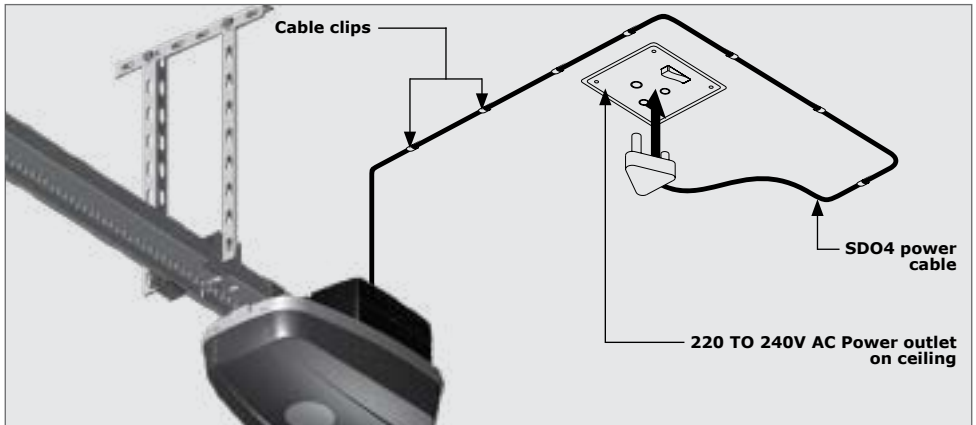

FIGURE 79

6.9. Defaulting the SDO4

Follow the below procedure to default the **SDO4** to its factory settings.



Please note that defaulting the SDO4 will clear its setting memory, therefore any operating parameters will be set to default values and Limits/Force settings are deleted. Remotes are NOT deleted.

1. Remove all power by disconnecting the mains and batteries.
2. Hold Learn (RED) while applying power to the control board.
3. Wait until the display shows "Fr", then release the button.

7. Electrical setup of accessories

- Two out (Power) and two in (Trigger and Safety beams) terminals are provided to support the connection of the most common external accessories
- The output terminals can be accessed by removing the screw above the control panel, and hinging down the power head cover (Item 4 - Figure 85).

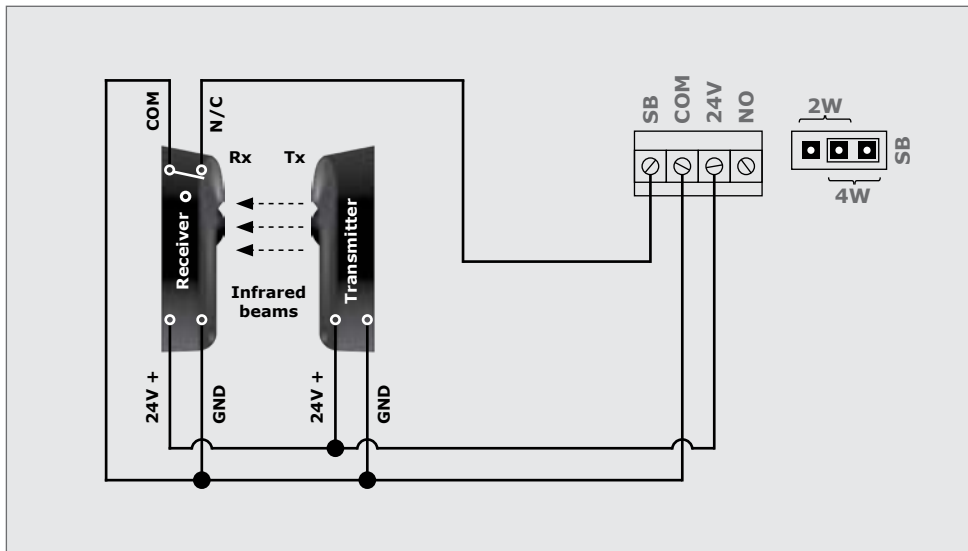

FIGURE 80. WIRING I5 SAFETY BEAMS TO THE SDO4 (FOUR-WIRE)

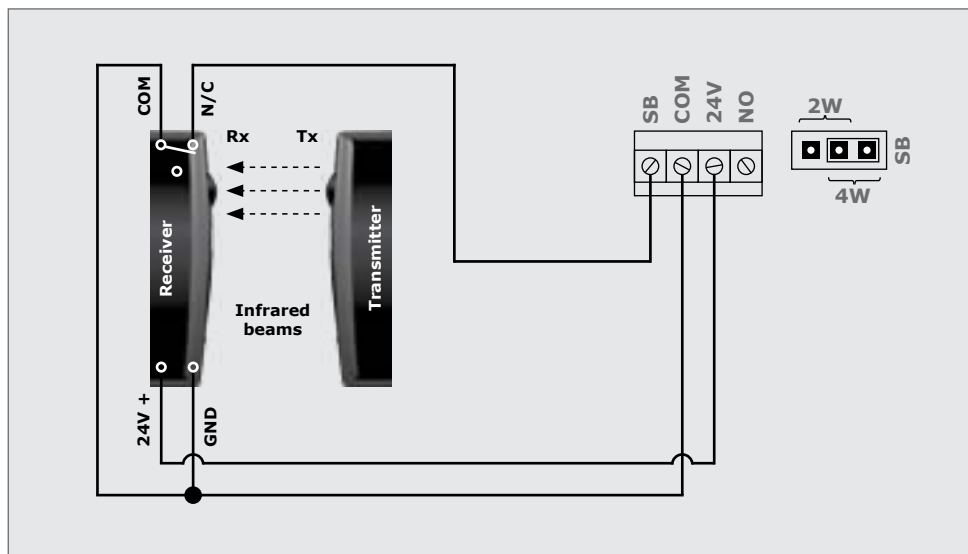

FIGURE 81. WIRING PHOTON SAFETY BEAMS TO THE SDO4 (FOUR-WIRE)

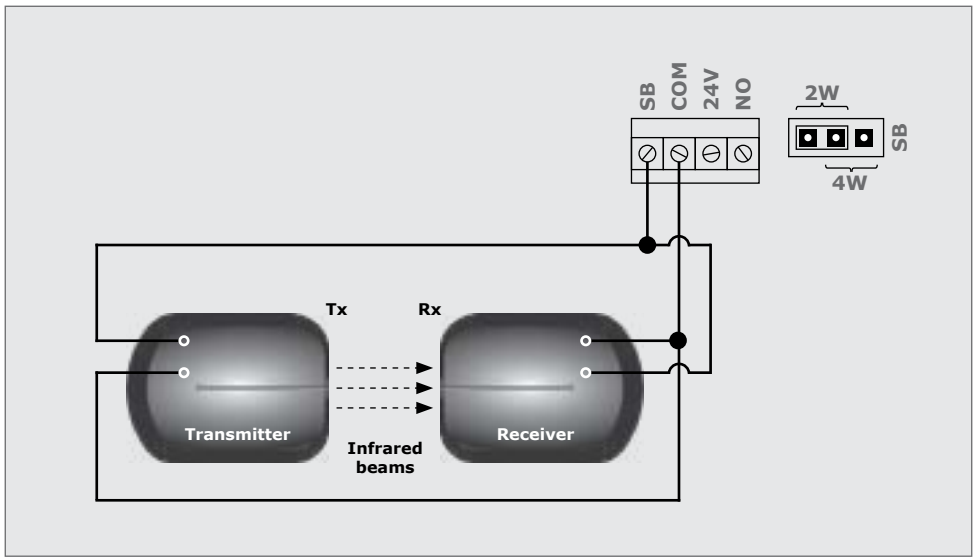

FIGURE 82. WIRING TWO-WIRE SAFETY BEAMS TO THE SDO4

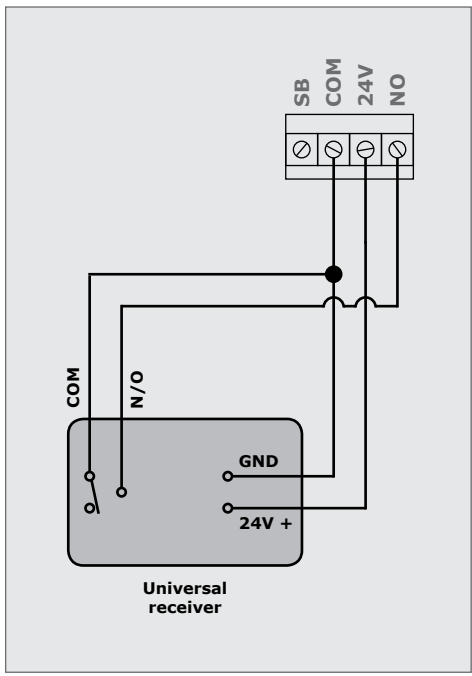

FIGURE 83. WIRING A UNIVERSAL RECEIVER TO THE SDO4

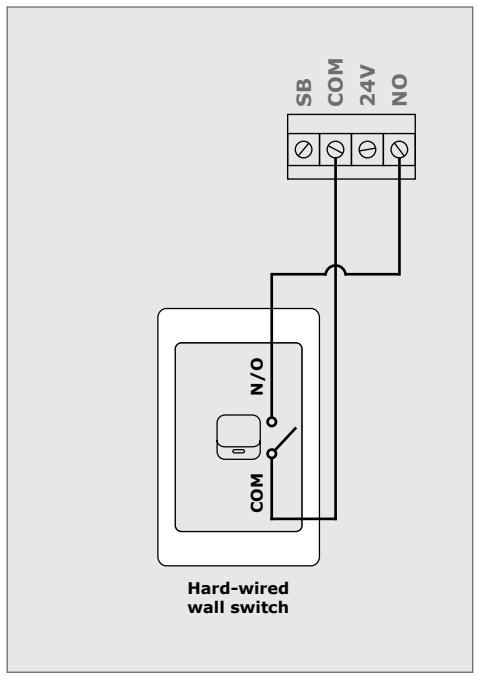

FIGURE 84. HARD-WIRING A WALL SWITCH TO THE SDO4

8. Commissioning the system

8.1. Control box

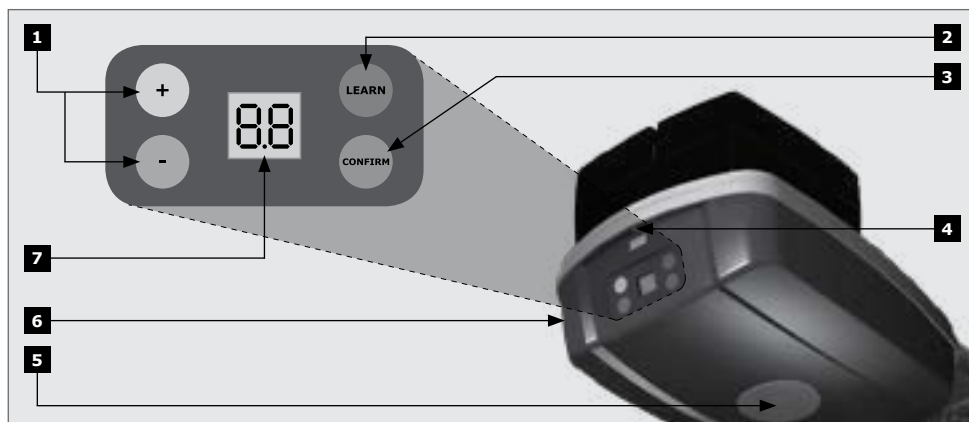

FIGURE 85

1. Yellow '+' button, and Blue '-' button.
 - **In Standby:** Decrease or increase force offset values
 - **Pressing '+' and '-' together:** Enters Function Setup menu
 - **In Function Setup menu:** Scroll functions and values
 - **In Transmitter Setup menu:** Scroll functions
2. Learn Button.
 - **Short Press:** Enters Transmitter Setup menu
 - **Long Press (5 sec):**
Forced relearn - Door can be in any position other than closed
Fine Tune - Door must be in the closed position
3. Confirm Button.
 - **In Standby:** Acts as a 'Run' button (Open and close the garage door)
 - **In Setup menus:** Confirm chosen function or value
4. Screw that keeps the power head cover in position. Remove the screw to hinge / remove the power head cover to gain access to terminals.
5. Courtesy LED light.
 - Acts as a 'Run' button (Open and close the garage door)
6. Control box of the **SDO4**
7. Display Screen

8.2. Selecting the door type



By default, the operator is set to "SE"; if this matches the door type being automated, the user may skip to "Setting the limits" by pressing the "Light Button".

1. Connect the mains and power up the unit.
2. "LL" & "SE" will flash alternately on the screen.
3. Use the "+" & "-" buttons to navigate between the following options:

- "tu" if the unit is being installed on a Tip-Up door
 - "SE" if the unit is being installed on a Sectional door
Press the "Green" Confirm button to select the correct option.
4. After door type has been selected, only L.L will be displayed. The dot in-between indicates that the door type has been selected.
 5. To adjust the position of the door (after door type has been selected) the "+" can be used to move the door up and "-" to move the door down before initiating the limit setup.

8.3. Setting the limits



Ensure that the Stoppers are correctly placed and tightened. Refer to Section 6.3.



Modifying the position of the door. The limits must be started from approximately the midway position. Should the door be within approximately 200mm of the closed position, use the "+" button by pressing and holding it down to drive the door to the midway position then start the limit setup.

8.3.1. Entering Limit setup mode

1. Press the "Green" confirm button, and the operator will start the limit learning procedure. The door will fully close, fully open, and fully close again. It has now learned where the open and closed positions are.
2. The LED Display will no longer display "LL" and the Courtesy Light will stop flashing; it will now display a "." (Dot).



IMPORTANT!!

Before the user can modify the position of the door they would have needed to complete "Section 8.2 - Selecting the door type".

8.3.2. Fine tuning the CLOSED position

- Drive door into Closed Position
- Press "Learn" for 5 seconds until display shows "CL"
- Adjust the Closed Position by pressing "+" (moves the door to the open position); or "-" (moves the door to the closed position). Each Press equals 3mm of travel
- To confirm new Closed Position, press "Confirm"

8.3.3. Safety Force Adjustment

The **SDO4** automatically adjusts the safety during the limit setup. This can be adjusted as follows:

8.3.3.1. Adjust Safety Offset Value

- At any time Press "+" or "-". The current Safety Offset Value is shown.
- Press "+" to increase or "-" to decrease Value,
 - F1 being the most sensitive
 - F5 being the least sensitive
- To confirm new Safety Offset Value Press "Confirm"
- To exit without changes wait 10 seconds or press "Learn"

8.3.3.2. Set Safety Offset Value to Maximum

- For installation where maximum power and less sensitivity is required –
 - Set the Safety Offset Value to "F5"
 - If F5 is still too sensitive, set Full power mode to On. Refer to menu



With Safety Offset set to Maximum, the door is dangerous and it is recommended that Safety Beams be used.

8.3.4. Safety Force testing

8.3.4.1. Testing open direction safety obstruction force value (Adaptive Mode)

1. With the garage door in the fully closed position, stand in the middle of the garage doorway and just behind the path of the garage door.
2. Activate the **SDO4** so that the garage door begins to open.
3. When the garage door has opened to approximately 450mm from the ground, apply some firm downward force to one of the structural members of the garage door.
4. If the safety obstruction force value is correct, the **SDO4** will stop the garage door upon sensing the applied force (safety stop). If too little or too much force is required to make the **SDO4** stop - Adjust the safety offset as required (Refer to Section 9.2.3.1.).

8.3.4.2. Testing closed direction safety obstruction force value (Adaptive Mode)

1. With the garage door in the fully open position, stand in the middle of the garage doorway and just behind the path of the garage door.
2. Ensure that the closed limit travel adjustment has been set so that bottom of the garage door rests against the ground.
3. Place a 32mm thick block of wood under the line of the garage door (approximately at the midpoint of the garage door) so that the garage door will close onto the block of wood.
4. Activate the **SDO4** so that the garage door begins to close.
5. If the safety obstruction force value is correct, the **SDO4** will stop and reverse the direction of the garage door upon encountering the block of wood (safety reverse).
6. If too little or too much force is required to make the **SDO4** safety reverse, - Adjust the safety offset as required (Refer to Section 8.3.3.).

8.3.5. Automatic re-learn

- A re-learn of drive force and run time parameters will be automatically initiated immediately subsequent to any of the following occurrences;
 - Run time deviation becoming excessive
 - Safety reversing on three consecutive occasions
 - Safety stopping on three consecutive occasions
- During this period, the LED indicator will quick flash, and the display will show "rL"

9. Programming remote controls

The **SD04** offers seven menu levels pertaining to six different functions that can be activated either via a handheld remote control or via the four-button wireless wall switch. Each menu level and function has a different effect upon the controller and the load which it controls. In addition, a seventh menu can be accessed which will learn the buttons of a four-button remote control or wall switch in the order described below.

9.1. Entering 'Learn' mode

9.1.1. Using the Learn button

Momentarily press the Learn button. The LED Display will display "00"¹ to confirm that the user is in the programming menu. Scroll using the '+' and '-' buttons to choose desired function. When desired function is selected, press and hold transmitter button for approximately 5 seconds. The Courtesy light will stop flashing to indicate a valid RF signal. The remote is now learned into the system. The number of beeps indicates the function that has been learned.

9.1.2. Using a Remote Transmitter.

Only transmitter buttons learned into "Light Function / Remote Learning" can initiate remote learning. Press and hold transmitter button for approximately 5 seconds. The courtesy light will flash and the display will show 'ru'. Scroll using the '+' and '-' buttons to choose the desired function. When the desired function is selected, press and hold the transmitter button. The Courtesy light will stop flashing to indicate a valid RF signal. The remote is now learned into the system. The number of beeps indicates the function that has been learned.

Any button can be set to control the **Trigger, Courtesy light, Holiday Lockout, Autoclose Override, Open Only, or Close Only** features.



The system will remain in this learn mode for 10 seconds after the last remote or wall transmitter button has been learned and automatically exit after this time. A function can be learned to any button, provided that the button has not yet been learned to another function.

1. With an empty memory, '00' will be displayed, otherwise it will display the number of remotes learned into the system.

9.2. Operating Functions

9.2.1. Run Function - Open / Stop / Close

This function is associated with opening, stopping and closing the door only.

Operation

Momentarily press the associated remote control button to open, stop or close the door.

If the door is busy closing, pressing the remote control button will cause the door to stop and a second press will reverse its direction of travel and start opening.

If, on the other hand, the door is busy opening, pressing the remote control button will cause the door to stop. Pressing the remote control button a second time will cause the door to reverse its direction of travel and start closing.

Learning procedure

Enter Learn mode, (Refer 9.1). Using the '+' and '-' buttons, select 'ru'. Press and hold the transmitter button until the display flashes "ru" and the buzzer beeps once.

9.2.2. Light Function / Remote Learning.

Learning a button to Function Two will enable that button to switch the courtesy light on and off, or learn in additional remotes.

Operation

- First Operation:
Momentarily press the associated remote control button to either switch the courtesy light on or off. If the light has been switched on, it will time out as per the maximum current timer of 2 minutes.
- Second Operation:
Press and Hold the associated remote control button to enter Remote Learn Mode. Refer Section 10.1

Learning procedure

Enter Learn mode (Refer 10.1). Using the '+' and '-' buttons, select 'li'. Press and hold the transmitter button until the display flashes 'li' and the buzzer beeps twice.

9.2.3. Holiday Lockout Function

Electronically lock the controller for use. In other words, no transmitters or inputs, other than those learned for Holiday Lockout Mode, will be able to trigger the operator.

Operation

To engage Holiday Lockout Mode, the button learned to engage this function must be pressed for three seconds before Holiday Lockout Mode will engage. The courtesy light will emit a single flash and the onboard buzzer, a single beep.

When the door reaches the closed position, the courtesy light will remain ON, and time out as per normal. Should a button which operates a function other than any of those associated with Holiday Lockout Mode be pressed whilst the operator is locked, the onboard buzzer will emit a single beep and the courtesy light will triple flash.

To disengage Holiday Lockout, press any button on any transmitter that has been learned for Holiday Lockout, and will emit a double beep, and two flashed to indicate it has been disabled.

Learning procedure

Enter Learn mode (Refer 10.1). Using the '+' and '-' buttons, select 'ho'. Press and hold the transmitter button until the display flashes 'ho' and buzzer beeps three times.

9.2.4. Autoclose Override Function

This function will allow the associated button to override the Autoclose function if it has been selected, resulting in the door staying open.

Operation

- With the door in the closed position, the Autoclose Override button must be pressed and held for at least three seconds to engage / activate this function. The light will flash quickly a number of times and simultaneously the buzzer will emit multiple beeps to confirm the operation of this function
- The door will also operate to open and stay open without Autoclosing
- Pressing the open / close button will trigger the door to close

Learning procedure

Enter Learn mode (Refer 10.1). Using the '+' and '-' buttons, select 'ao'. Press and hold the transmitter button until the display flashes "ao" and buzzer beeps four times.

9.2.5. Learn all buttons function

If function five is selected, all the buttons of a remote control or wall switch will be learned in the following configuration and sequence:

1. Button 1 – Open/Stop/Close
2. Button 2 – Light
3. Button 3 – Lock
4. Button 4 – Autoclose override

Operation

The operation of Function Five will be according to the four different functions described previously.

Learning procedure

Enter Learn mode (Refer 10.1). Using the '+' and '-' buttons, select 'bu'. Press and hold the transmitter button until the display flashes 'bu' and the buzzer beeps five times.

9.2.6. Open Only Function

This function allows associated button to only open the door.

Operation

Momentarily pressing the associated button will open the door from any position. If the door was closing the door will stop and re-open. This function has no effect if the door is open.

Learning procedure

Enter Learn mode (Refer 10.1). Using the '+' and '-' buttons, select 'oo'. Press and hold the transmitter button until the display flashes 'oo' and the buzzer beeps six times.

9.2.7. Close Only Function

This function allows associated button to only close the door.

Operation

Momentarily pressing the associated button will close the door from any position. If the door was opening the door will stop and close. This function has no effect if the door is closed.

Learning procedure

Enter Learn mode (Refer 10.1). Using the '+' and '-' buttons, select 'co'. Press and hold the transmitter button until the display flashes 'co' and the buzzer beeps seven times.

9.3. Deleting remote controls

- Remote controls can be deleted at any stage



Following this procedure will remove all remote controls and transmitters from the SDO4's memory.

1. In standby mode (only a "." [Dot] displayed on the LED Display), press the "Red" Learn button once.
 2. The LED Display will display "00" to confirm that the user is in the programming menu.
 3. Press and Hold green "Confirm" button until the Light Flashes; when the screen displays "dL", all remotes have been successfully deleted.
1. With an empty memory, '00' will be displayed, otherwise it will display the number of remotes learned into the system.

10. SDO4 Features

10.1. Menu Navigation map

Menu	Menu Description	Default Value	Value Description
Sb	Safety Photo Beam	OF	OF - Disable Safety Beam On - Enable Safety Beam in Closed Direction 2d - Enable Safety Beam in Open and Closed Direction
AC	Autoclose Function	OF	OF - Disabled Autoclose 05 - 5 sec / 30 sec 15 - 15 sec / 90 sec 30 - 30 sec / 180 sec (A sec / B sec : A= after Safety Beam alignment, B = if no Safety Beam trigger)
dt	Door Type	SE	SE - Sectional Door tu - Tip-up Door
SS	Slow stop	Sh	Sh - Short slow stop Lo - Long slow stop
FP	Full power	OF	OF - Standard Power On - Full Power
Li	Courtesy Light time	02	01 - 1 minute 02 - 2 minute 03 - 3 minute
Pr	Partial reverse	ON	On - Partial reverse after Obstruction OFF - Full reverse after Obstruction
Sr	Signal reverse	OF	On - Reversing mode OF - Standard mode
ds	Door Service Monitor	OF	OF - Disabled ON - Monitors and indicates if door is not Balanced
rt	Maximum Run time	30	30 - 30 sec Run time 60 - 60 sec Run time
bj	Back Jump	ON	OF - Disabled ON - After reaching Closed motor drives back 3mm

TABLE 4

10.1. Safety Beams (Sb)

The installation of safety beams greatly enhances safety by constantly monitoring for persons or objects which may pass within the path of the moving garage door.

Safety Beam Menu (Sb) has the following settings:

- OFF - Safety Beams are disabled
- ON - While closing, the door will stop and re-open if the Safety Beams are triggered
- 2d - While closing, the door will stop and re-open if the Safety Beams are triggered. While the door is opening, the door will stop and retract 30mm

10.2. Autoclose (ac)

- Autoclose can enhance the security of your property by ensuring that your garage door is never unintentionally left open
- Autoclose will automatically close the garage door from any open position based on the time set and whether Safety Beams have been triggered

Autoclose Time Setting	Safety Beams Triggered	Safety Beams NOT Triggered
05	5 seconds	30 seconds
15	15 seconds	90 seconds
30	30 seconds	180 seconds

TABLE 5



Autoclose will only function when used in conjunction with safety beams.

10.3. Back Jump (bj)

- Back jump will reverse the closed garage door by an incremental amount (1 - 5mm) in order to reduce motor gear lock-up and ensure effortless disengagement in the event of power outage

10.4. Motor Supply

- The **SD04** is a battery-driven appliance.
- In the event of a power outage, the batteries can provide up to 30 cycles of operation



Batteries will suffer permanent damage if not charged within a three month period while remaining connected to the controller.

10.4.1. Mains Fail Warning

- In the event of a power outage, the Buzzer will beep twice every 30 seconds while the operator is moving

10.4.2. Shutdown Mode

- In the event of a prolonged power outage, the **SDO4** will automatically shut down in order to conserve the remaining charge in the batteries, and prevent battery damage. The LED indicator will stop flashing and the **SDO4** will cease to function
- Shutdown will occur when the power is not active and once battery voltage falls below 23.5V
- If the **SDO4** is triggered while in Shutdown Mode, the Buzzer will beep three times to indicate Shutdown Mode and the operator will not operate

10.4.3. Solar power

- An optional solar power kit is available. Some modifications may be necessary. Contact Centurion Systems (Pty) Ltd for further information

10.4.4. Warning buzzer

- An audible buzzer will;
 - Double 'beep' every 30 seconds to indicate that the power supply is not active
 - Triple 'beep' every 30 seconds to indicate that the power supply is not active and that remaining battery voltage is low and therefore Shutdown is imminent. (The operator does not operate)

10.5. Courtesy Light

- The built-in courtesy light switches on every time that the **SDO4** is activated, then switches off automatically, 120 seconds (2 minutes) after receiving the last hand transmitter or run signal (See section 10.2.2.)

LED Light replacement

1. Remove control box cover.
2. Unplug the LED light harness from controller.
3. Using a 3mm flat screw driver, unclip the LED light pcb.
4. Clip the new LED light PCB and connect to controller.



The courtesy light will not function once battery voltage drops below 24 volts.

10.6. Safety Reverse (pr)

- Partial safety reverse ensures that the garage door does not open fully and thereby present an unwanted security risk.
 - ON - The door partially reverses on detecting obstruction
 - OFF - The door fully reverses on detecting obstruction
- In the event that the garage door encounters a sufficient obstruction during a close cycle, the **SDO4** will immediately stop and then begin to reverse direction and stop after three seconds. Upon receiving a signal immediately subsequent to partial safety reverse, the **SDO4** will recommence movement in the open direction

10.7. Soft Start

When commencing movement from any stationary position, the **SDO4** will slowly ramp up to full speed. This is in order to minimise start-up load on the **SDO4** and garage door and provide smooth and quiet operation.

10.8. Slow Stop (SS)

By intelligently reducing the speed of the garage door as it approaches a limit point, the **SDO4** ensures quieter garage door closing and prolongs **SDO4** and garage door life.

10.8.1. Long Slow Stop

The **SDO4** slows down appropriately 300-350mm before end of travel. The door will also move significantly slower in "crawl" state.

10.8.2. Short Slow Stop

The **SDO4** slows down appropriately 150mm-200mm before end of travel.

10.9. Door Type (dt)

- SE - Sectional door
- tu - Tip-up door

10.10. Reversing Mode (Signal Reverse "Sr")

When switched ON trigger impulse from Transmitter or Input will reverse the direction of a moving garage door. If it is closing, it will stop and immediately begin opening.

10.11. Door Service monitor (DSM)

- Door Service Monitor will monitor the spring balance of the garage door by logging the run time differential between open and close cycles
- The display will show 'E3' and the buzzer will short beep five times once the run time differential exceeds three seconds. At this point the garage door should be serviced by a suitably qualified technician

10.12. Run Time

The maximum run time for the operator is adjustable to 30 seconds or 60 Seconds. In the event that the motor runs longer than the run time, the display will show "E4" and the buzzer will beep five times.

10.13. Full Power

Full Power increases the maximum current that the controller applies to the motor. This enables the **SDO4** to operate rough-running garage doors.



With Safety Offset set to Maximum the door is dangerous and it is recommended to use Safety Beams.

11. Troubleshooting

If an error occurs, the courtesy LED will triple flash and an error code will be displayed on the screen.

Error code	Description	Possible Solution
E1	Safety Beam Active	Align Safety Beams, Check connections, select two-wire or four-wire safety beams with corresponding jumper.
E2	Safety Strip Advice	This is not applicable to SA operators.
E3	Door Imbalanced	Check door tension (Door Service monitor).
E4	Run Time Exceeded	Ensure that correct door type is selected (SE - Sectional, tu - Tip-up).
E5	Current Sensor	The door is too heavy for current force setting, increase the force offset value. Refer to "8.3.3.1. Adjust Safety Offset Value"
E6	Collision	Check door tension, guide rails for any obstructions.
E7	Not enough power supplied to the operator	Check batteries and PSU. Operator cannot run from PSU only.
E8	Drive fault	Check fuse, motor connection and drive circuit.
E9	DOSS fault	Check DOSS connection on PCB
Lb	Low Battery	Ensure batteries are charged / connected.

TABLE 6

12. 24 Month carry-in product warranty



You can register your product(s) online at www.centsys.co.za, which will assist you in keeping a record of your date of purchase or installation, serial numbers, etc.

All of our products are manufactured with extreme care, thoroughly inspected and tested.

The goods supplied by us shall be subject to the provisions of sections 55 to 57 of the Consumer Protection Act (68/2008) except where the provisions of the warranty contained in our product documentation are more favourable to the purchaser.

Subject to the warranty contained in our product documentation, if applicable, our products are warranted for a period of twenty-four months after delivery.

However, it is expressly noted that batteries carry a six month warranty due to the nature of these products being such that they are subject to possible misuse. Please note that warranties will be honoured on a carry-in basis; in other words, the product in question must be taken in to one of our branches, or to the authorised reseller that the product was purchased from, for assessment and, if necessary, repair. For equipment not of our manufacture, the warranty as supplied by the original manufacturer will apply if such warranty is more favourable to the purchaser than the relevant provisions of the Consumer Protection Act (Act 68/2008 of South Africa), or any other applicable law as so required in different countries in which the product was sold.

Such warranty is valid only once full payment has been received for such goods.

Any warranty may be voidable on any equipment which:

1. Has not been installed in accordance with the installation instructions provided.
2. Has been subject to misuse or which has been used for any purpose other than that designed for by the manufacturers.
3. Has damage caused as a result of handling during transit, atmospheric conditions (including lightning), corrosion of metal parts, insect infestation, power surges or other forces outside of the control of the manufacturer.
4. Has been repaired by any workshop and / or person NOT previously authorised by the manufacturer.
5. Has been repaired with components not previously tested, passed or authorised by Centurion Systems (Pty) Ltd, South Africa or one of its subsidiary companies.

13. Installation handover

Once the installation has been successfully completed and tested, it is important for the installer to explain the operation and safety requirements of the system.

NEVER ASSUME THE USER KNOWS HOW TO SAFELY OPERATE THE SDO4.

Neither Centurion Systems (Pty) Ltd, nor its subsidiaries, accepts any liability caused by improper use of the product, or for use other than that for which the product was intended.

Ensure that the user is in possession of the user guide and that you have completed the installation details in the back of the user guide.

The following needs to be understood by the user:

- How to operate the manual release mechanism. (Show them how by demonstration)
- How the obstruction detection and all other safety features work. (Show them how by demonstration)
- All the features and benefits of the operator, i.e. Beams, etc.
- All the safety considerations associated with operating an automated garage door. The users should be able to pass this knowledge on to all other users of the automated system and must be made aware of this responsibility.
- Do not activate the garage door operator unless you can see it and can determine that its area of travel is clear of people, pets, or other obstructions
- **NO ONE MAY CROSS THE PATH OF A MOVING GARAGE DOOR.** Always keep people and objects away from the gate and its area of travel
- **NEVER LET CHILDREN OPERATE OR PLAY WITH THE GARAGE DOOR CONTROLS,** and do not allow children or pets near the garage door area
- Be careful with moving parts and avoid close proximity to areas where fingers or hands could be pinched
- Secure all easily-accessible garage door operator controls in order to prevent unauthorised use of the garage door
- Keep the automated garage door system properly maintained, and ensure that all working areas are free of debris and other objects that could affect the garage door operation and safety
- On a monthly basis, check the obstruction detection system and safety devices for correct operation
- All repair and service work to this product must be done by a suitably qualified person
- This product was designed and built strictly for the use indicated in this documentation. Any other use, not expressly indicated here, could compromise the good condition/operation of the product and/or be a source of danger!

Centurion Systems (Pty) Ltd does not accept any liability caused by improper use of the product, or for use other than that for which the automated system was designed.

Ensure that the customer is in possession of the User Guide and that you have completed the installation details in the back of the User Guide.



CENTURION

Connect with us on:

 facebook.com/centurionsystems

 YouTube.com/centurionsystems

 [@askcenturion](https://twitter.com/askcenturion)

Subscribe to the newsletter: www.centsys.com/subscribe

Call Centurion Systems (Pty) Ltd • South Africa
Head Office: +27 11 699 2400

Call Technical Support: +27 11 699 2481
from 07h00 to 18h00 (UTC+2)

E&OE Centurion Systems (Pty) Ltd reserves the right to change any product without prior notice

All product and brand names in this document that are accompanied by the ® symbol are registered trademarks in South Africa and/or other countries, in favour of Centurion Systems (Pty) Ltd, South Africa.

The CENTURION and CENTSYS logos, all product and brand names in this document that are accompanied by the TM symbol are trademarks of Centurion Systems (Pty) Ltd, in South Africa and other territories; all rights are reserved.

We invite you to contact us for further details.



Doc number: 1262.D.01.0001_4
8002-0029-02R(A)

www.centsys.com